



Supporting solar innovation
Patented systems

IDEAL SUPPORT
FOR PHOTOVOLTAIC MODULES
ON FLAT ROOFS



ASSEMBLY INSTRUCTIONS

INDEX

Introduction	Page
Indications for planning and dimensioning	03
Definitions and indications relating to safety	04
Sun Ballast assembly systems	05
Tools for assembly	05
Clamp predisposition	06
Standard system	07
Sail system	09
5° sail system horizontal	09
5° sail system vertical	11
11° sail system horizontal	13
Connect system	15
Valid for: 5°, 10°, 15°, 20°, 30° horizontal	15
5° Sail Connect	17
10° Connect vertical	19
East - West system	21
Cablowind	23
Additional Weight	25
U-shaped additional weight	25
Additional weight for standard system 0°.K	26
Double ballast	27
Use of polyurethane foam	29
Summary table	30
Responsibility	33
Warranty	34
Technical Requirements Declaration Sun Ballast - Ballast	34
Warranty on the Sun Ballast product - Ballast	35
Maintenance	36
Plant installation log	36
Maintenance performed log	37
FAC similar plant installation execution report	38

INDICATIONS FOR PLANNING AND DIMENSIONING

The Basic technicians can provide a report with the aim of ensuring that the proposed Sun Ballast system (modules, ballasts, any accessories), guarantees the necessary safety under the action of the wind acting on the panels.

Basic S.r.l. assumes no responsibility for any damage and / or problems to systems for which a correct study has not been carried out by an expert designer, and for which installation has not been carried out by expert technicians, also specifying that disclaim any responsibility deriving from incorrect or different installation of the system with respect to the Sun Ballast instructions, from the lack or absence of maintenance or from any other tampering that may in any case affect the statics of the system in question.

It will be the responsibility of the user / installer / construction manager to determine whether the product and accessories used are suitable for the intended use and suitable for the roof structure before installation / purchase; in addition, the user must carefully check that the installation phases of the system are carried out following the assembly instructions of Basic S.r.l.

It will therefore be the responsibility of the end user to proceed to appoint the installers, construction manager and professionals in order to provide state-of-the-art installations and tests.

With Sun Ballast it will be ascertained that the stabilizing forces produced by the structure are greater than the overturning forces produced by the pressure exerted by the wind.

It is advisable to view the technical data sheets of the Sun Ballast products on the site: www.sunballast.it



SAFETY

DEFINITIONS AND INDICATIONS RELATING TO SAFETY



DANGER: The inherent property or quality of a given factor that has the potential to cause harm.

WARNING: Notice, communicated, written and displayed in a public place or addressed directly to interested parties of a possible danger of death and / or serious injury.

PRECAUTION: Act or behavior aimed at avoiding an imminent or possible danger.

ATTENTION: Symbol that warns of material damage without possible injury.

Warning



Risk of falling

When working on roofs and during ascent and descent there is a risk of falls. It is essential that you observe the safety regulations and use adequate fall protections.



Injury to the hands and feet

During the assembly of the structure and forms there is a risk of injury and entrapment of the limbs.

Work shall only be carried out by appropriately trained personnel.
Use protective gloves and safety shoes.



Muscle strains and back injuries

Strictly follow the company rules regarding the manual handling of loads.

Falling objects

During assembly on the roof there is a risk that tools or assembly material may fall off the roof, causing injury to people and property underneath.

Before starting assembly work, delimit the danger zone below and warn people nearby not to approach.

During assembly, observe the local regulations, building regulations and accident prevention regulations. Observe the safety instructions of the other system components.

Failure to follow the instructions below can result in property damage and / or serious injury. Keep the assembly instructions.



SUN BALLAST ASSEMBLY SEQUENCE

CLAMPS PREDISPOSITION

Terminal clamp

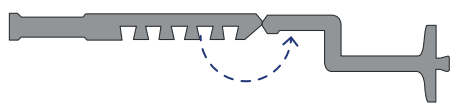

The terminal clamp is delivered in one piece.

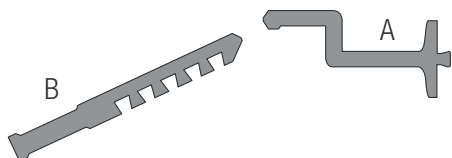

It is necessary to separate the two parts of the clamp.

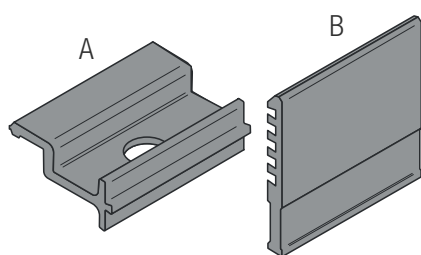

Insert part A into part B at the specific height for the panel you want to mount.

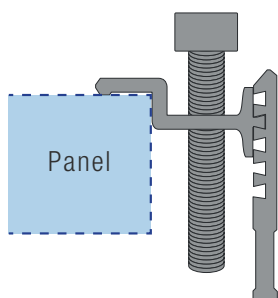
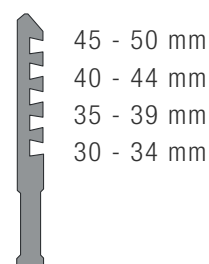

Screw the bolt in the clamp, tightening the panel (12-14 Nm)

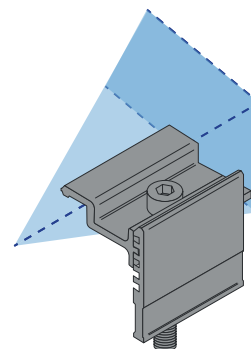

Central clamp

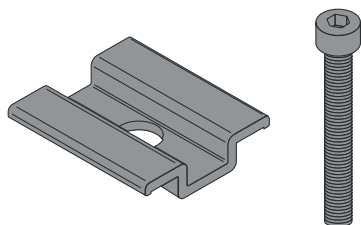

Screw the bolt in the clamp, tightening the panel (12-14 Nm)

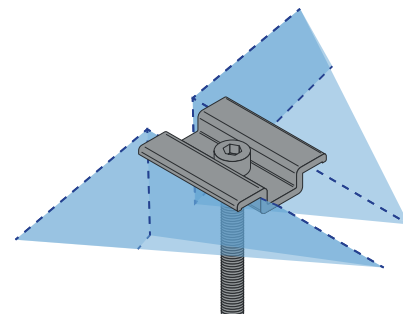

The applied torque must refer to the mechanical standard conforming to the bolt in use: with M8 stainless steel bolts use a tightening torque of 12/14 Nm.

Avoid impact wrenches: it is advisable to also consult the information indicated in the assembly sheet of the panel manufacturer.



SUN BALLAST ASSEMBLY SEQUENCE

STANDARD SYSTEM

Valid for: **0°K, 3°K, 5°, 10°, 10°SHED, 11°, 15°, 20°, 30°.1** - Panels orientation: **Horizontal / Vertical** -
 Double ballast: **YES** - Cablowind: **YES** - Additional Weight: **YES**

Phase 1: Laying of the sheaths

It is recommended to use a wire to position the sheaths linearly with respect to the system and to lay the same at the ends of the support surface of the ballast.

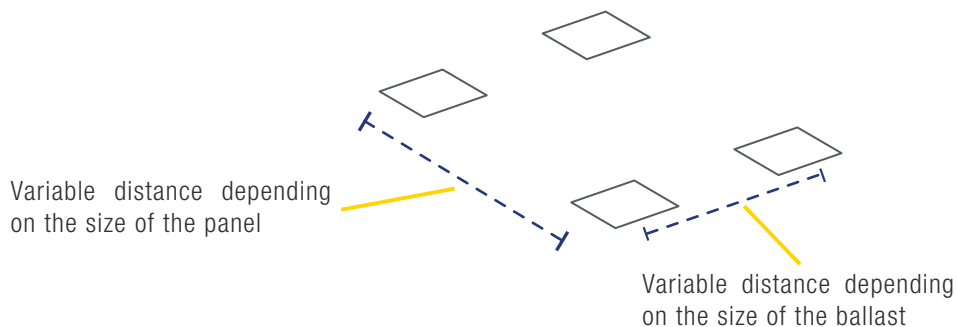

Phase 2: Laying of the ballast on the sheaths

To determine the distance between the ballast it is recommended to use the Dima, which takes the bushings on the same as a reference, considering a tolerance of ($\pm 2\text{cm}$)

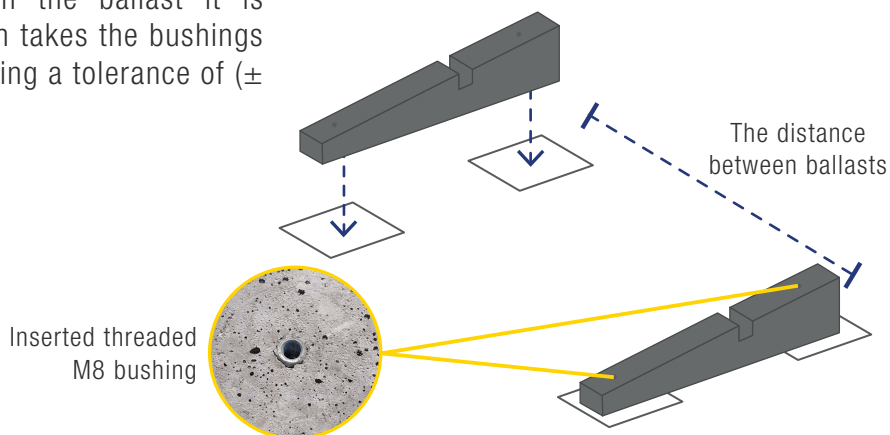

Phase 3: Laying of photovoltaic panels

Position the panels on the ballasts. We remind you that the panels can be installed horizontally or vertically depending on the design.

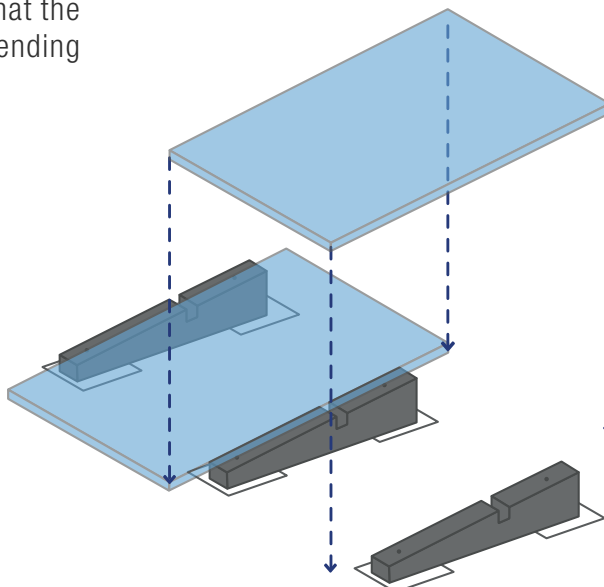

SUN BALLAST ASSEMBLY SEQUENCE

STANDARD SYSTEM

Valid for: 0°K, 3°K, 5°, 10°, 10°SHED, 11°, 15°, 20°, 30°.1 - Panels orientation: **Horizontal / Vertical** -
 Double ballast: **YES** - Cablowind: **YES** - Additional Weight: **YES**

Phase 4: Fixing the panels with terminal and central clamps

Use the terminal and central clamps arranged as indicated in the dedicated sheet.

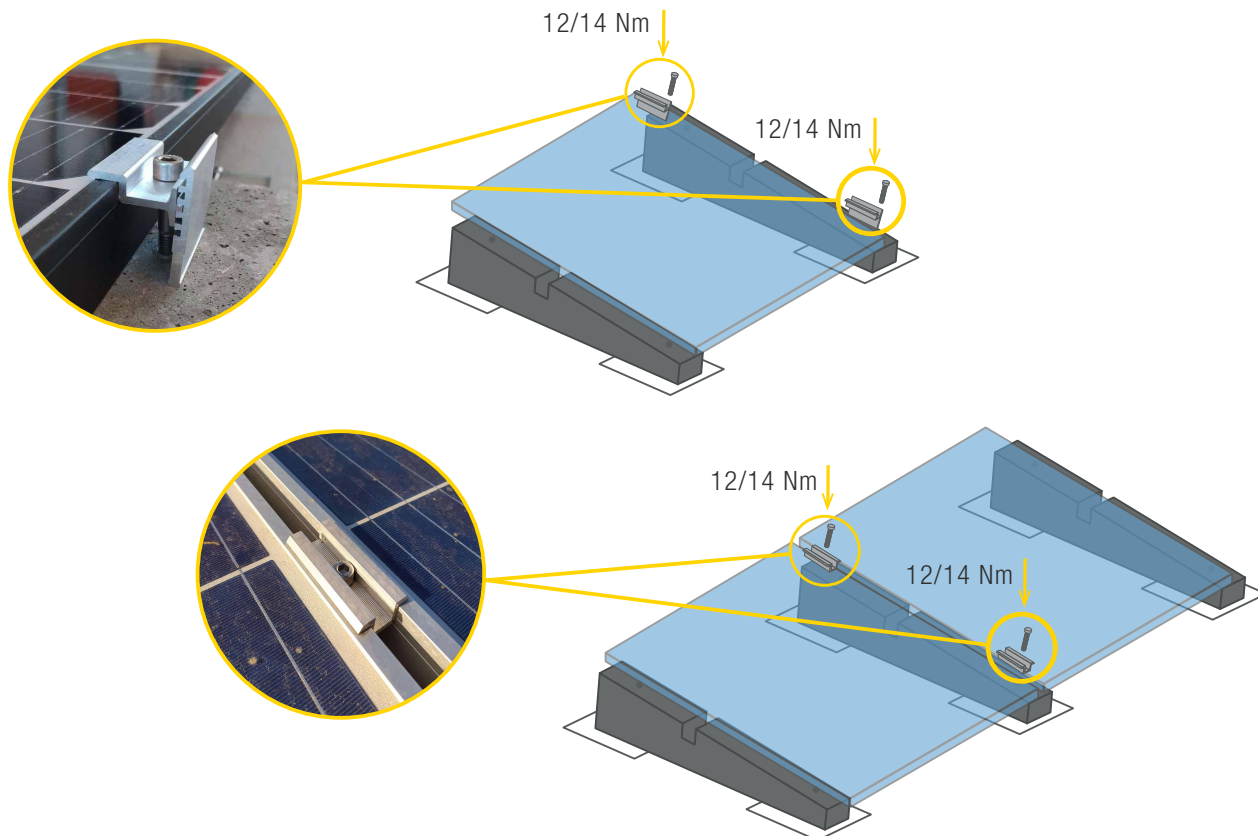

The applied torque must refer to the mechanical standard conforming to the bolt in use: with M8 stainless steel bolts use a tightening torque of 12/14 Nm.

Avoid impact wrenches: it is advisable to also consult the information indicated in the assembly sheet of the panel manufacturer.

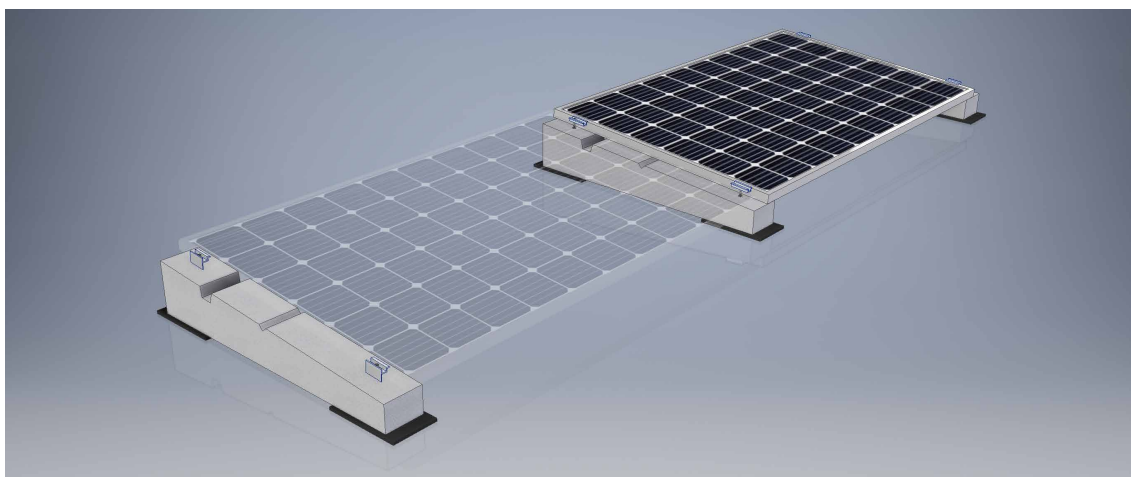

SUN BALLAST ASSEMBLY SEQUENCE

SAIL-SHAPED SYSTEM 5°

Double ballast: **YES** - Single row: **YES** - Panels orientation: **Horizontal** - Cablowind: **NO** - Additional Weight: **YES**

Phase 1: Laying of the sheaths

It is recommended to use a wire to position the sheaths linearly with respect to the system and to lay the same at the ends of the support surface of the ballast.

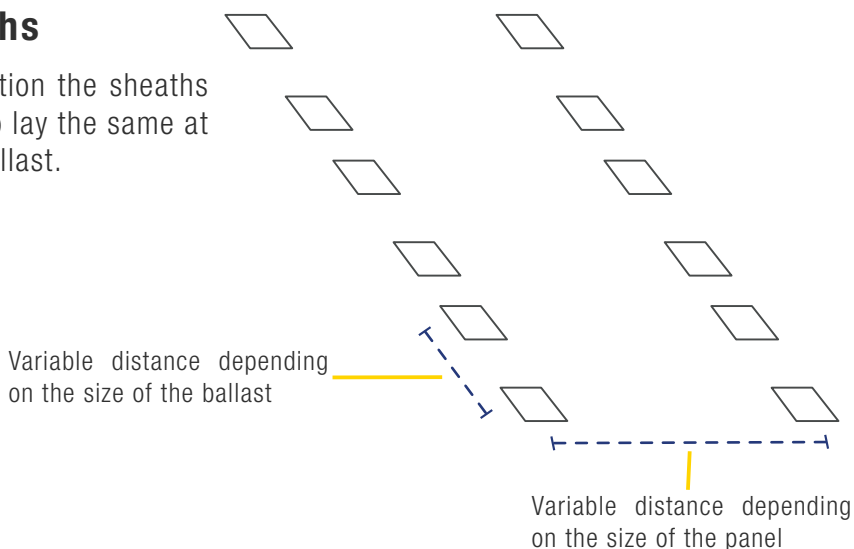

Phase 2: Laying of the ballast on the sheaths

To determine the distance between the ballast it is recommended to use the Dima, which takes the bushings on the same as a reference, considering a tolerance of ($\pm 2\text{cm}$)

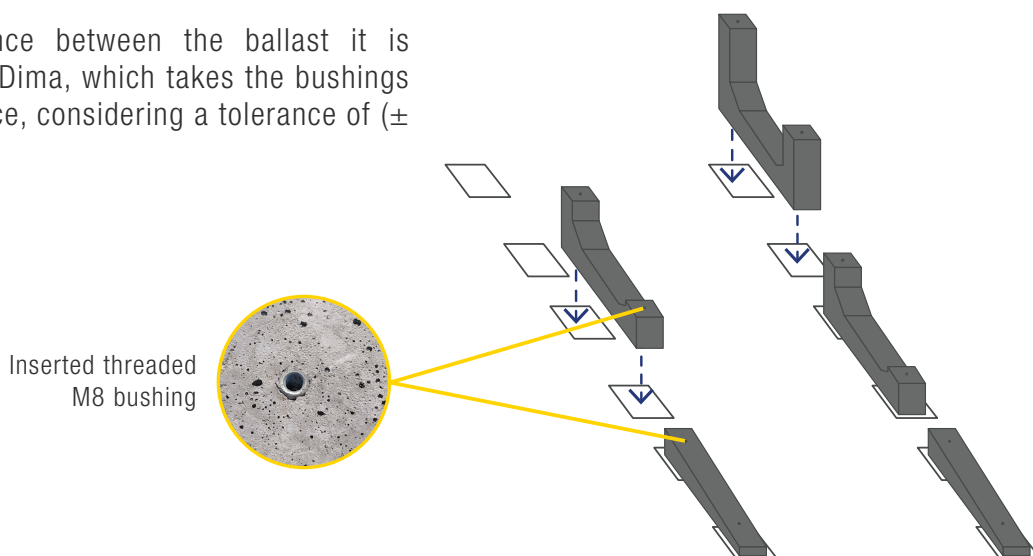

Phase 3: Positioning the junction plate of the sail-shaped system

Position the junction plates in correspondence with the M8 holes on the ballasts.

The junction plates are optional and must be installed only if foreseen by the project.

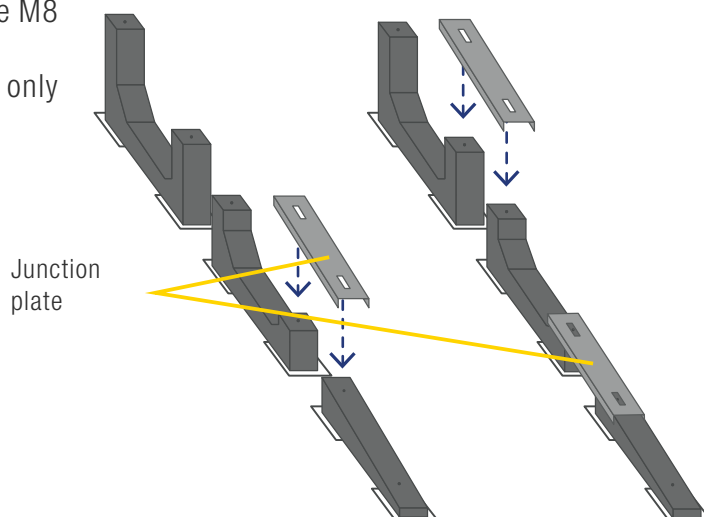

SUN BALLAST ASSEMBLY SEQUENCE

SAIL-SHAPED SYSTEM 5°

Double ballast: **YES** - Single row: **YES** - Panels orientation: **Horizontal** - Cablowind: **NO** - Additional Weight: **YES**

Phase 4: Fixing the panels with terminal and central clamps

Place the panels on the ballasts.

Use the terminal and central clamps prepared as indicated on the dedicated sheet.

The same clamps are used to fix the junction plates.

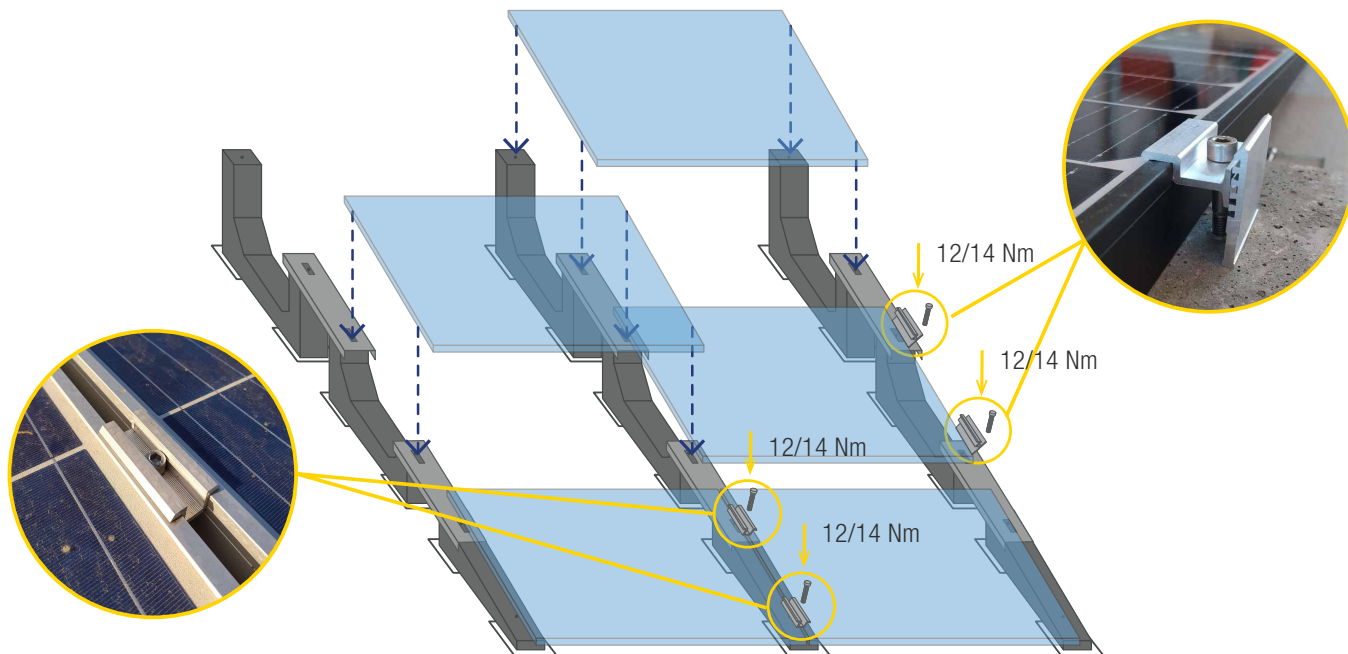

The applied torque must refer to the mechanical standard conforming to the bolt in use: with M8 stainless steel bolts use a tightening torque of 12/14 Nm.

Avoid impact wrenches: it is advisable to also consult the information indicated in the assembly sheet of the panel manufacturer.

Section with junction plates

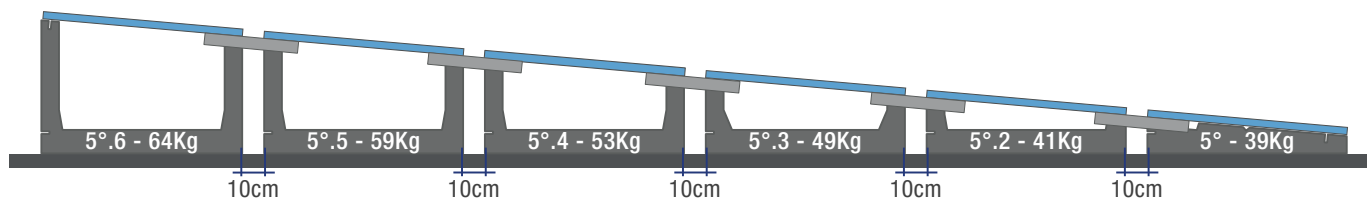

Section without junction plates

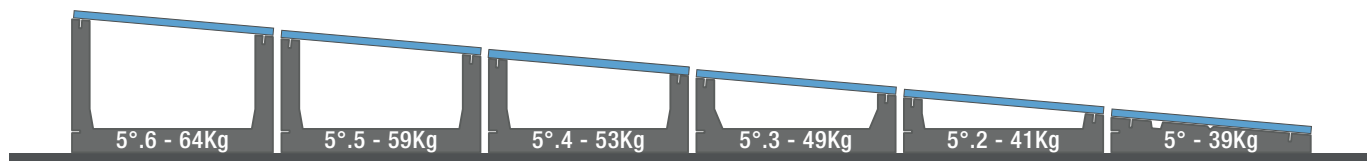

SUN BALLAST ASSEMBLY SEQUENCE

SAIL-SHAPED SYSTEM 5°

Double ballast: **YES** - Single row: **YES** - Panels orientation: **Vertical** - Cablowind: **SI** - Additional Weight: **YES**

Phase 1: Laying of the sheaths

It is recommended to use a wire to position the sheaths linearly with respect to the system and to lay the same at the ends of the support surface of the ballast.

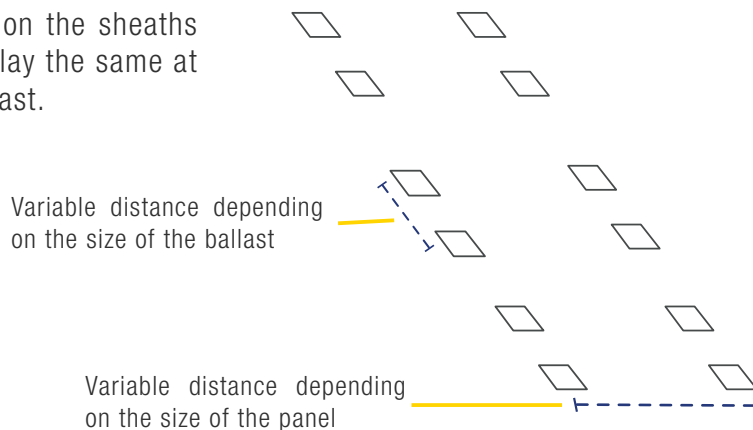

Phase 2: Laying of the ballast on the sheaths

To determine the distance between the ballast it is recommended to use the Dima, which takes the bushings on the same as a reference, considering a tolerance of ($\pm 2\text{cm}$)

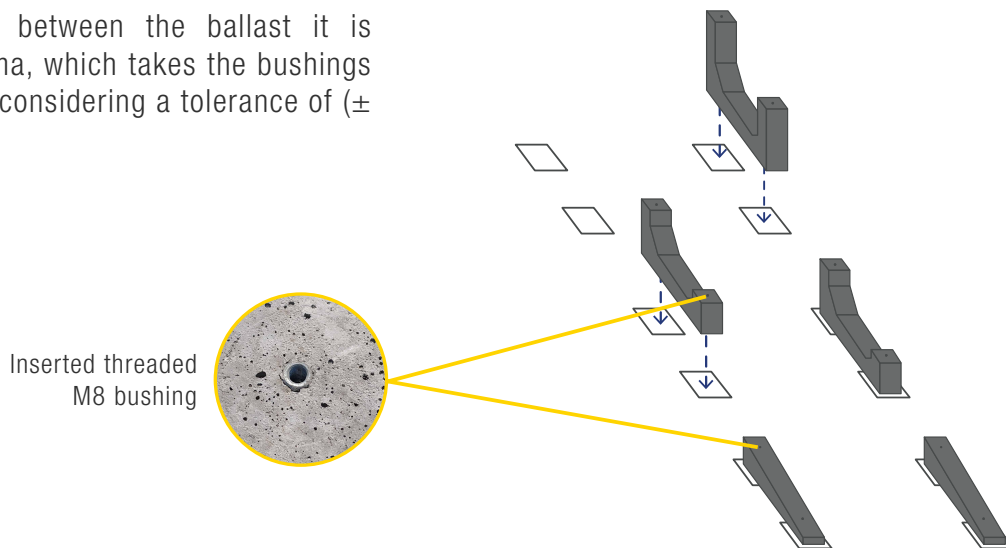

Phase 3: Laying of photovoltaic panels

Position the panels on the ballasts.

In order to avoid the shading of the panels, it is advisable to further space the rows following what is indicated in the project.

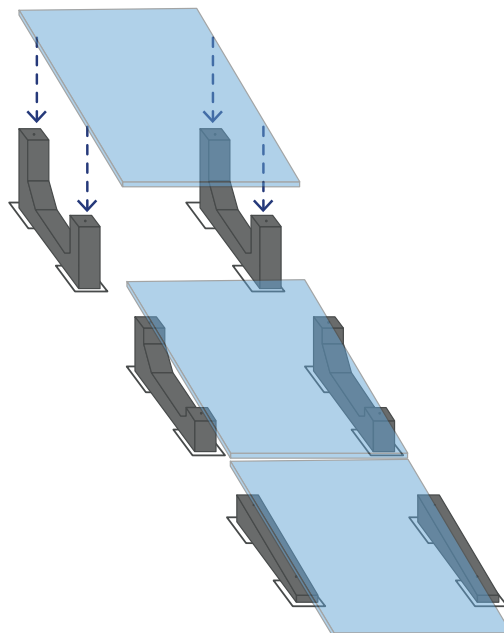

SUN BALLAST ASSEMBLY SEQUENCE

SAIL-SHAPED SYSTEM 5°

Double ballast: **YES** - Single row: **YES** - Panels orientation: **Vertical** - Cablowind: **SI** - Additional Weight: **YES**

Phase 4: Fixing the panels with terminal and central clamps

Use the terminal and central clamps prepared as indicated on the dedicated sheet.

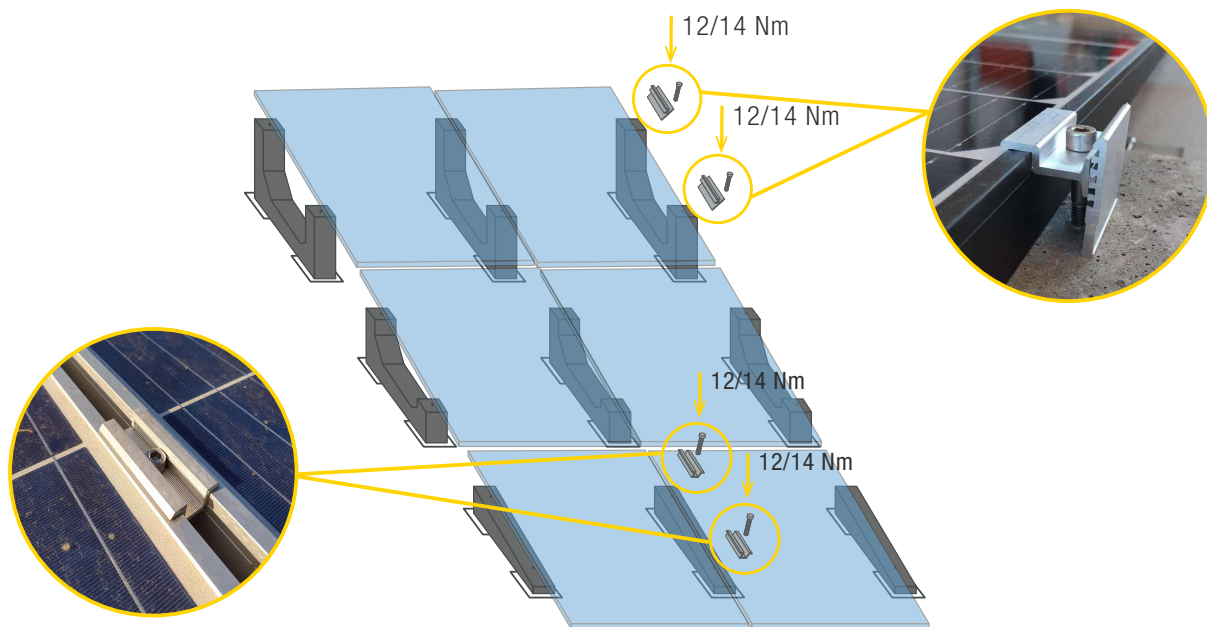

The applied torque must refer to the mechanical standard conforming to the bolt in use: with M8 stainless steel bolts use a tightening torque of 12/14 Nm.

Avoid impact wrenches: it is advisable to also consult the information indicated in the assembly sheet of the panel manufacturer..

Section

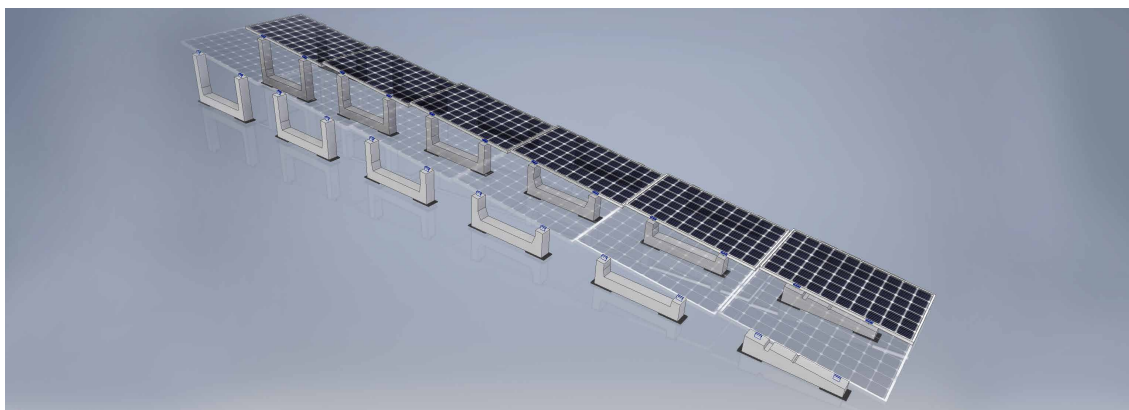
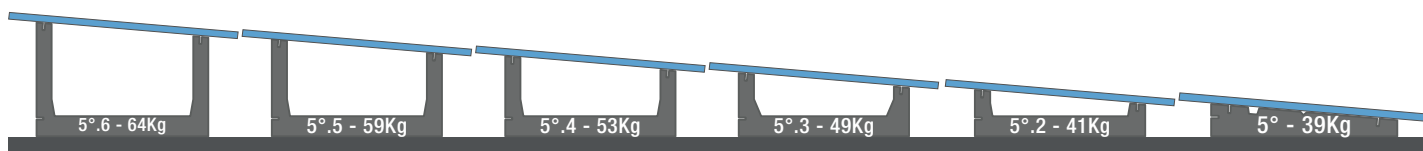

SUN BALLAST ASSEMBLY SEQUENCE

SAIL-SHAPED SYSTEM 11°

Double ballast: **YES** - Single row: **YES** - Panels orientation: **Horizontal** - Cablowind: **YES** - Additional Weight: **YES**

Phase 1: Laying of the sheaths

It is recommended to use a wire to position the sheaths linearly with respect to the system and to lay the same at the ends of the support surface of the ballast.

The distance between one ballast and the other varies:

from 22 to 23 cm for the first row

from 30 to 34 cm for the second row.

(see the image of the section)

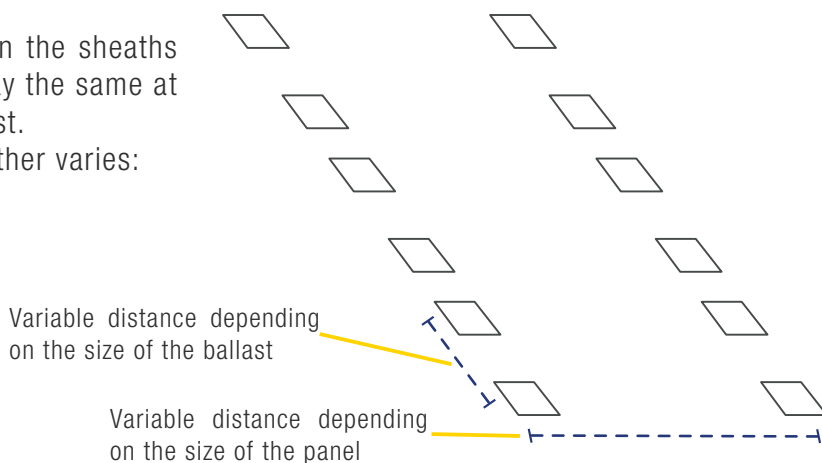

Phase 2: Laying of the ballast on the sheaths

To determine the distance between the ballast it is recommended to use the Dima, which takes the bushings on the same as a reference, considering a tolerance of (± 2 cm)

Inserted threaded M8 bushing

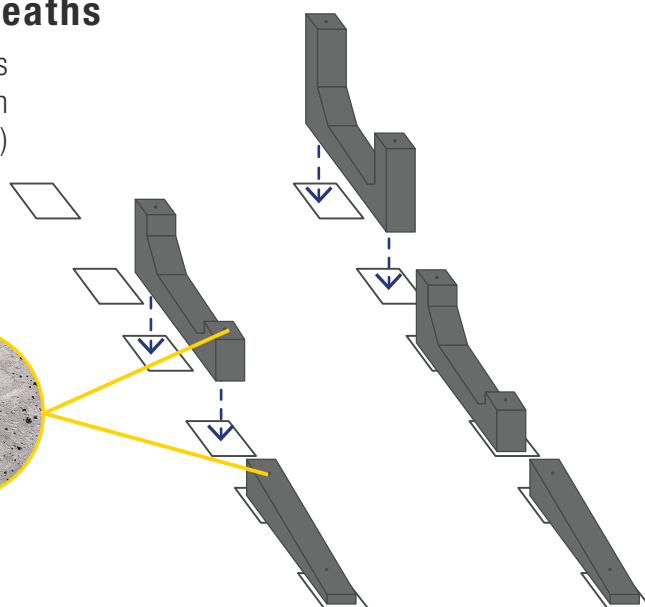

Phase 3: Positioning the junction plate of the sail-shaped system

Position the junction plates in correspondence with the M8 holes on the ballasts.

The junction plates are optional and must be installed only if foreseen by the project.

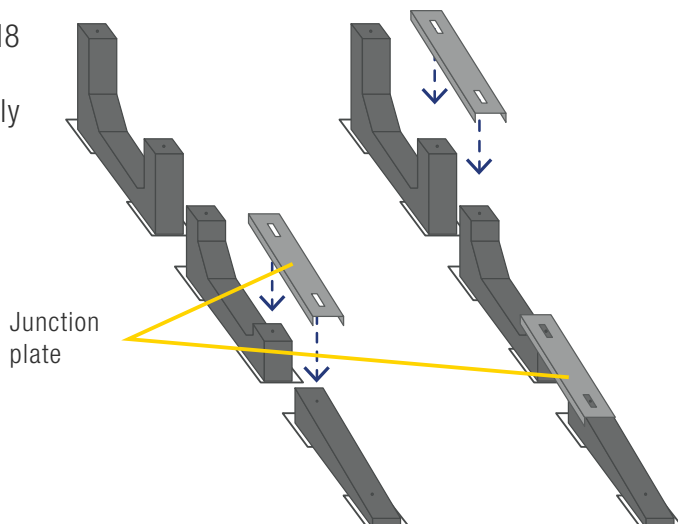

SUN BALLAST ASSEMBLY SEQUENCE

SAIL-SHAPED SYSTEM 11°

Double ballast: **YES** - Single row: **YES** - Panels orientation: **Horizontal** - Cablowind: **YES** - Additional Weight: **YES**

Phase 4: Fixing the panels with terminal and central clamps

Place the panels on the ballasts.

Use the terminal and central clamps prepared as indicated on the dedicated sheet.

The same clamps are used to fix the junction plates.

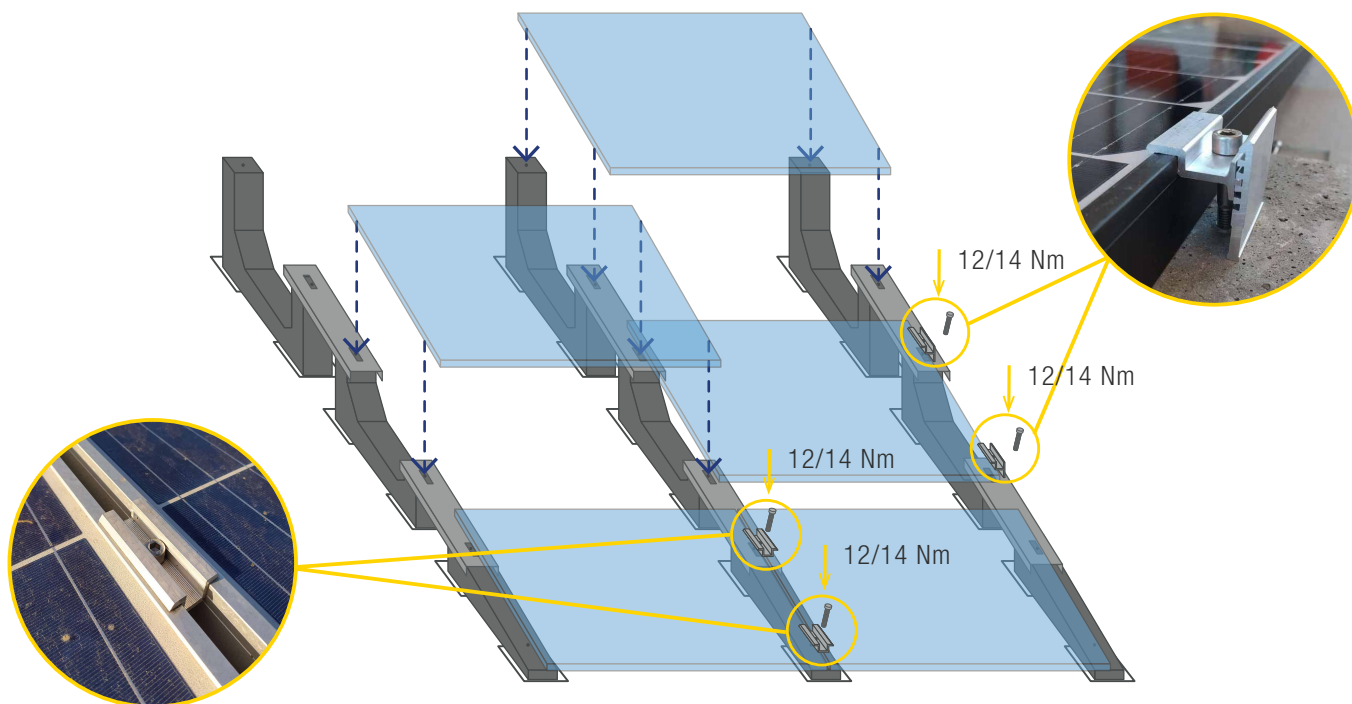

The applied torque must refer to the mechanical standard conforming to the bolt in use: with M8 stainless steel bolts use a tightening torque of 12/14 Nm.

Avoid impact wrenches: it is advisable to also consult the information indicated in the assembly sheet of the panel manufacturer.

Section with junction plates

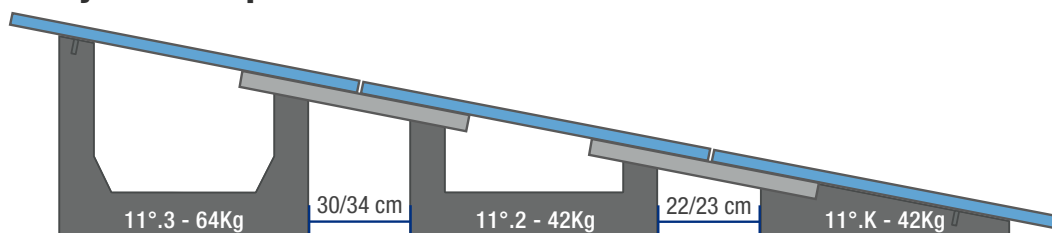

Section without junction plates

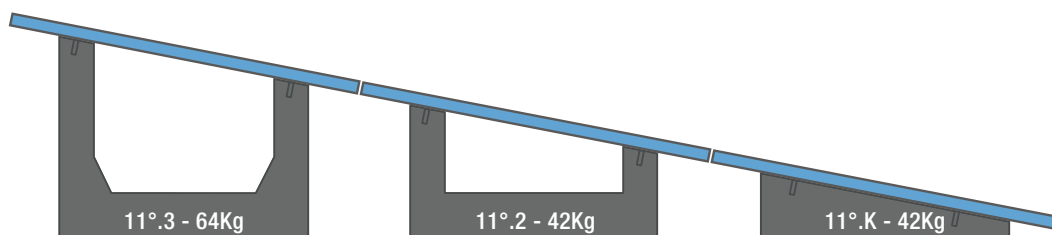

SUN BALLAST ASSEMBLY SEQUENCE

CONNECT SYSTEM

Valid for: **5°, 10°, 15°, 20° e 30°** - Panels orientation: **Horizontal** - Double ballast: **YES** - Cablowind: **NO** - Additional Weight: **YES**

Phase 1: Laying of the sheaths

It is recommended to use a wire to position the sheaths linearly with respect to the system and to lay the same at the ends of the support surface of the ballast.

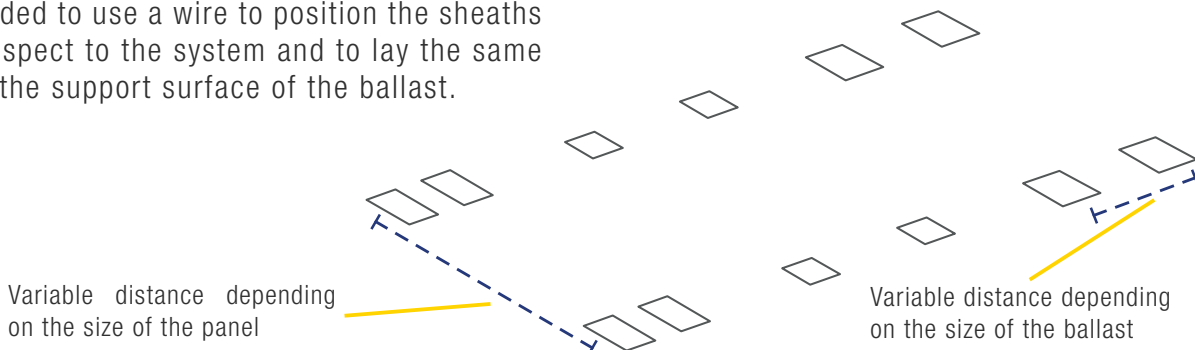

Phase 2: Laying of the ballast on the sheaths

When positioning the ballast, start with the CF or CRT following the installation diagram.

To determine the distance between the ballast it is recommended to use the Dima, which takes the bushings on the same as a reference, considering a tolerance of ($\pm 2\text{cm}$)

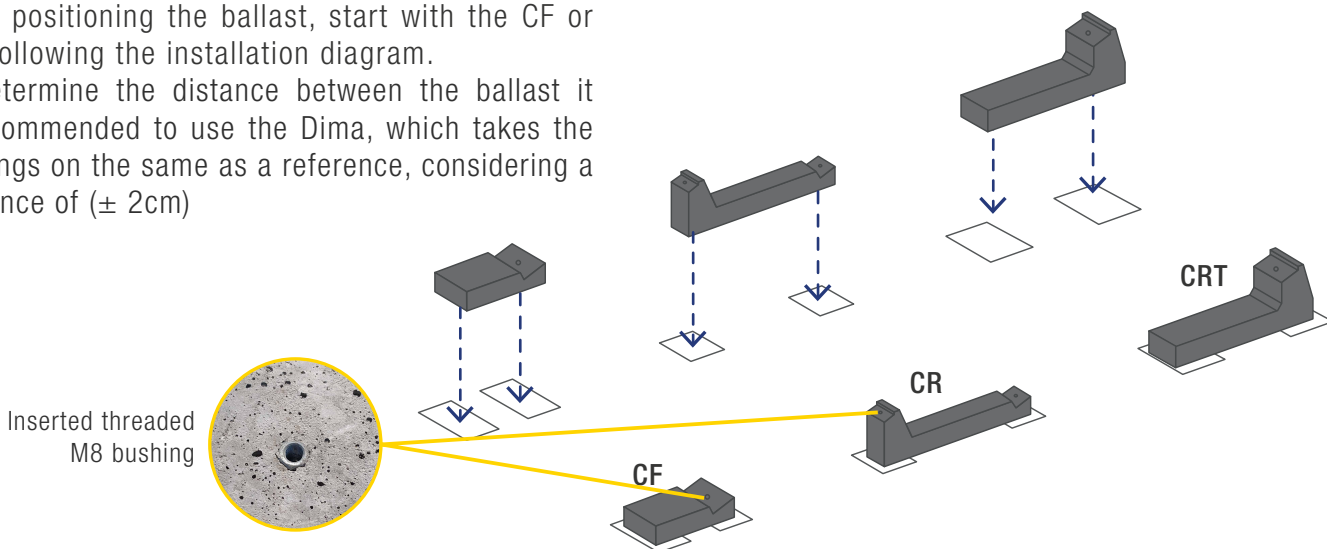

Phase 3: Installation of photovoltaic panels

Position the panels on the ballasts.

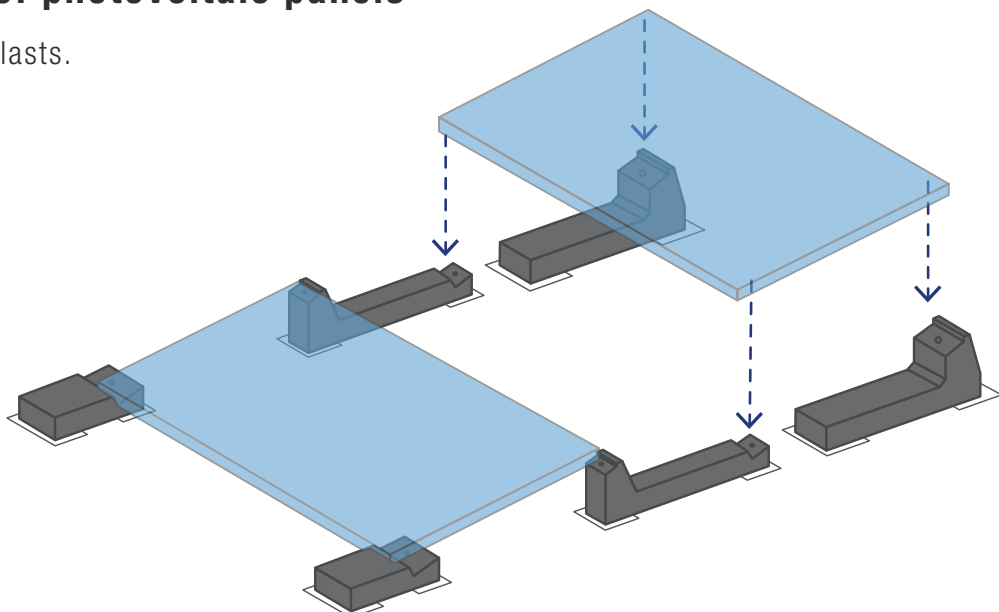

SUN BALLAST ASSEMBLY SEQUENCE

CONNECT SYSTEM

Valid for: **5°, 10°, 15°, 20° e 30°** - Panels orientation: **Horizontal** - Double ballast: **YES** - Cablowind: **NO** - Additional Weight: **YES**

Phase 4: Fixing the panels with terminal and central clamps

Use the terminal and central clamps prepared as indicated on the dedicated sheet.

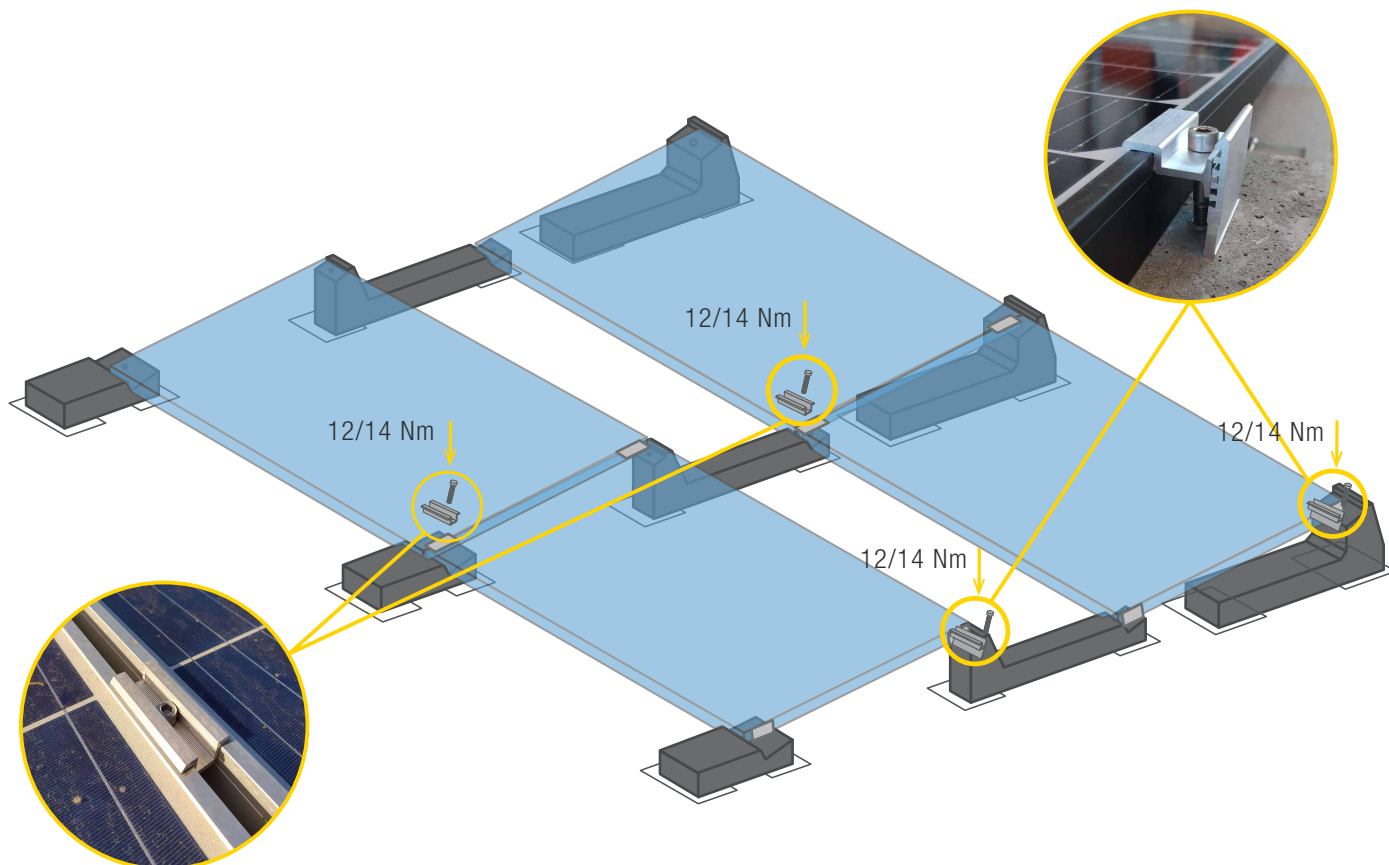

The applied torque must refer to the mechanical standard conforming to the bolt in use: with M8 stainless steel bolts use a tightening torque of 12/14 Nm.

Avoid impact wrenches: it is advisable to also consult the information indicated in the assembly sheet of the panel manufacturer.

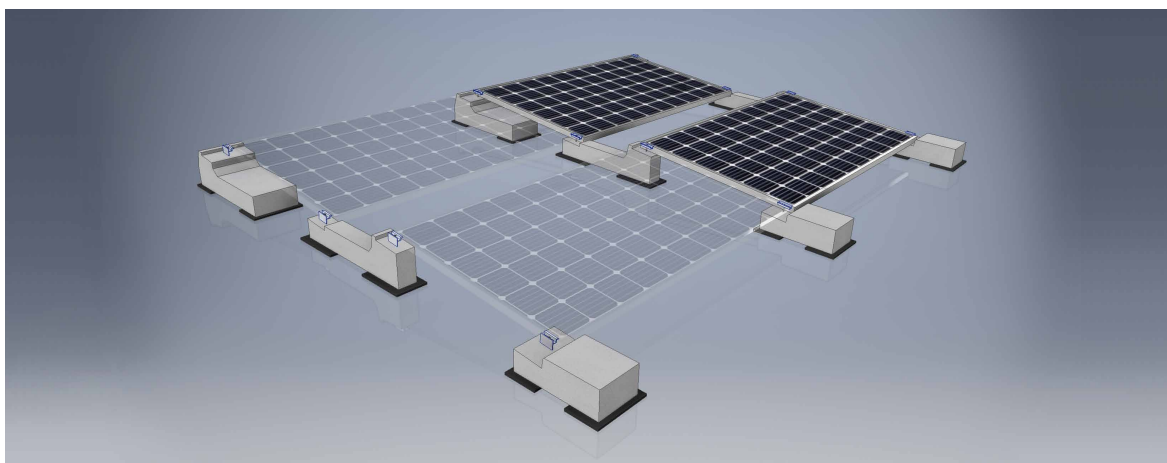

SUN BALLAST ASSEMBLY SEQUENCE

CONNECT SYSTEM

Valid for: **connect sail-shaped 5°** - Panels orientation: **Horizontal** - Double ballast: **YES** - Cablowind: **NO** - Additional Weight: **YES**

Phase 1: Phase 2: Laying of the ballast (CF e CRC) on the sheaths

It is recommended to use a wire to position the sheaths linearly with respect to the system and to lay the same at the ends of the support surface of the ballast.

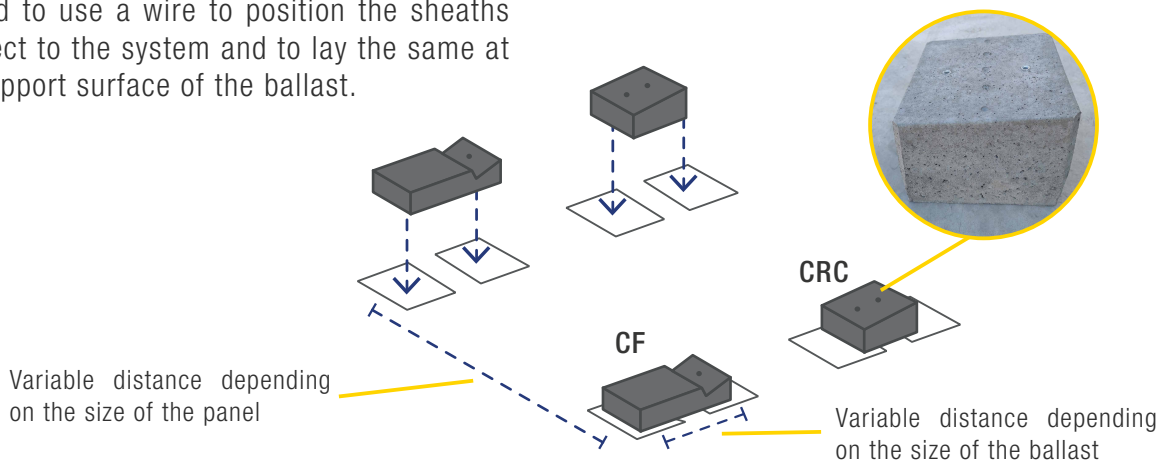

Phase 2: Installation of photovoltaic panels

It is advisable to use a wire or the positioning dima in order to carry out a linear installation and proceed gradually from the first row to continue with the following rows.

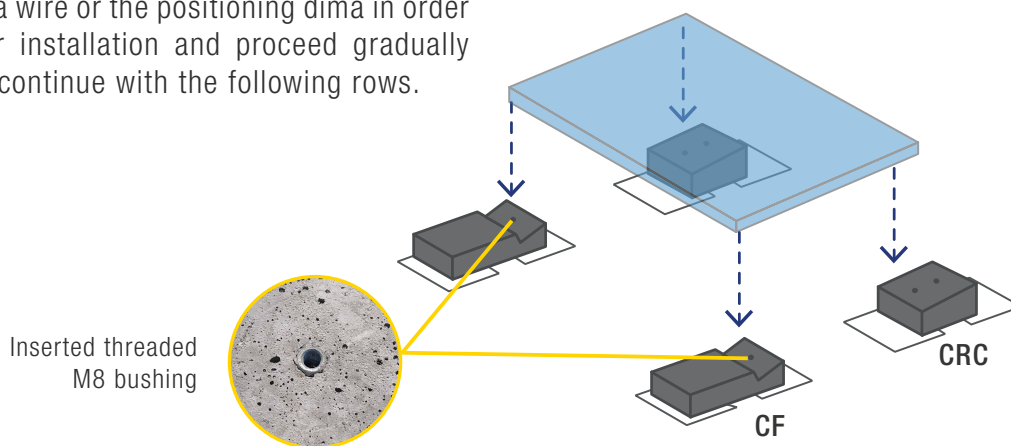

Phase 3: Laying of the ballast (CRR) on the sheaths and panels

Position the panels on the ballasts.

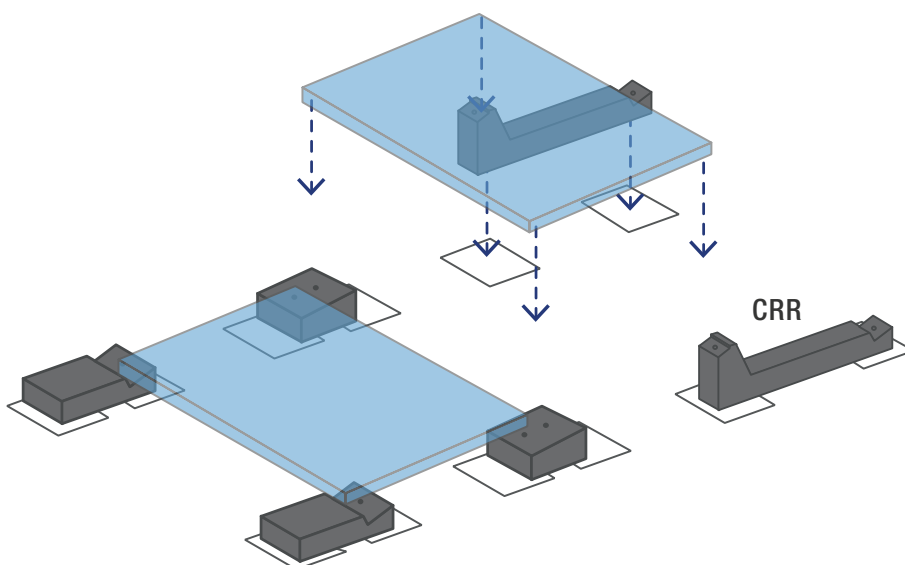

SUN BALLAST ASSEMBLY SEQUENCE

CONNECT SYSTEM

Valid for: **connect sail-shaped 5°** - Panels orientation: **Horizontal** - Double ballast: **YES** - Cablowind: **NO** -
Additional Weight: **YES**

Phase 4: Laying of central (CRC) and terminal (CRTT) ballasts

Position the panels and complete the fixing with terminal and central clamps.

Please note: If the CRSS ballast is used in the system, take into account the greater shading of the panels.

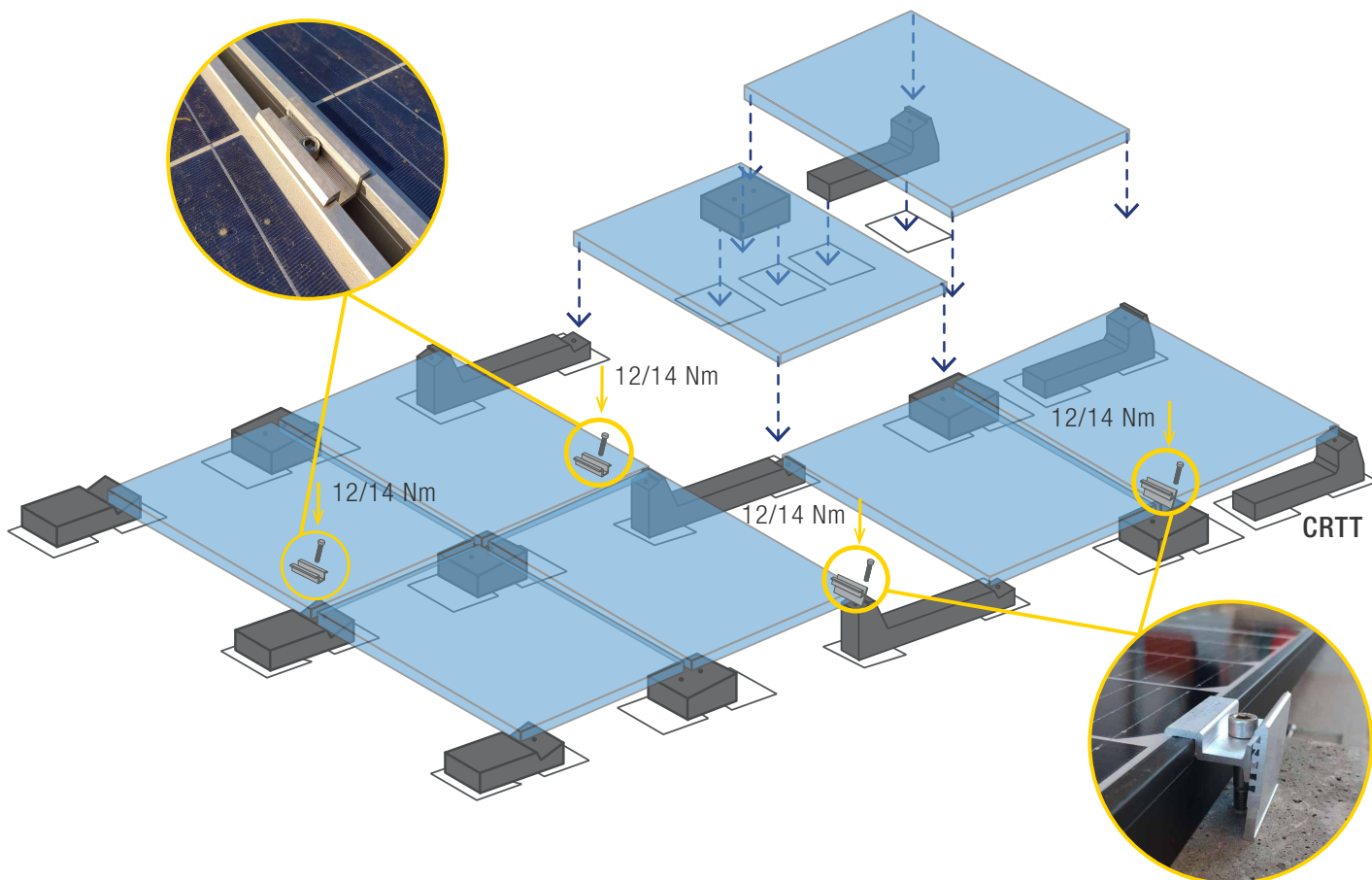

The applied torque must refer to the mechanical standard conforming to the bolt in use: with M8 stainless steel bolts use a tightening torque of 12/14 Nm.

Avoid impact wrenches: it is advisable to also consult the information indicated in the assembly sheet of the panel manufacturer.

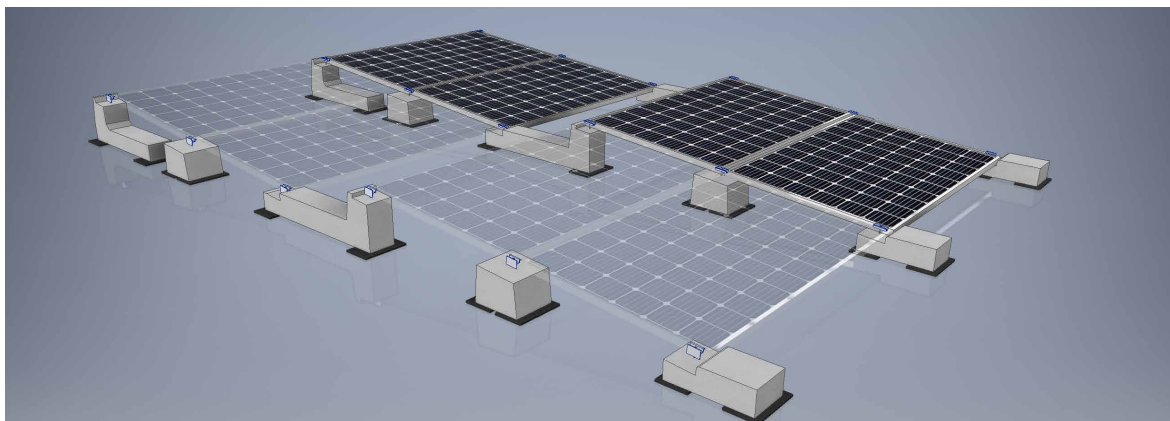

SUN BALLAST ASSEMBLY SEQUENCE

CONNECT SYSTEM

Valid for connect: **10°** - Panels orientation: **VERTICAL** - Double ballast: **YES** - Cablowind: **NO** -
Additional Weight: **YES**

Phase 1: Laying of the sheaths

It is recommended to use a wire to position the sheaths linearly with respect to the system and to lay the same at the ends of the support surface of the ballast.

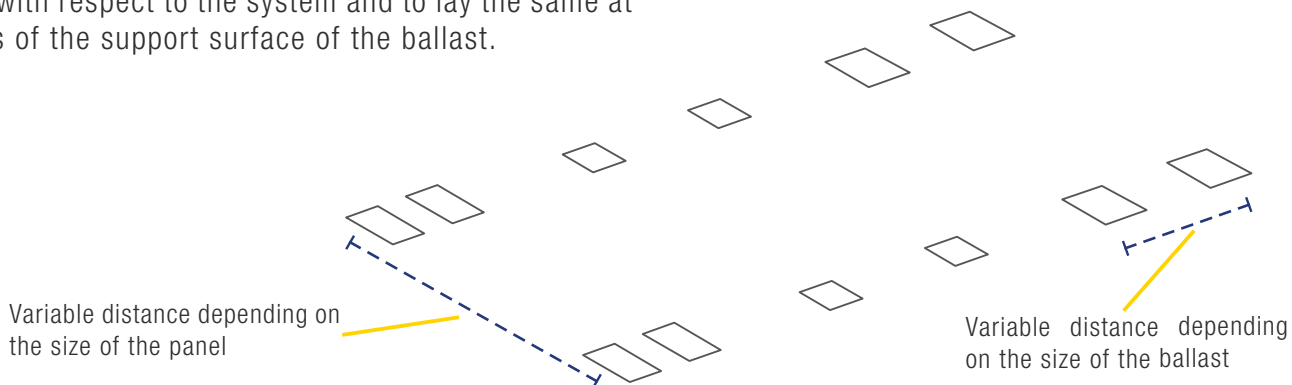

Phase 2: Laying of the ballast on the sheaths

To determine the distance between the ballast it is recommended to use the Dima, which takes the bushings on the same as a reference, considering a tolerance of ($\pm 2\text{cm}$)

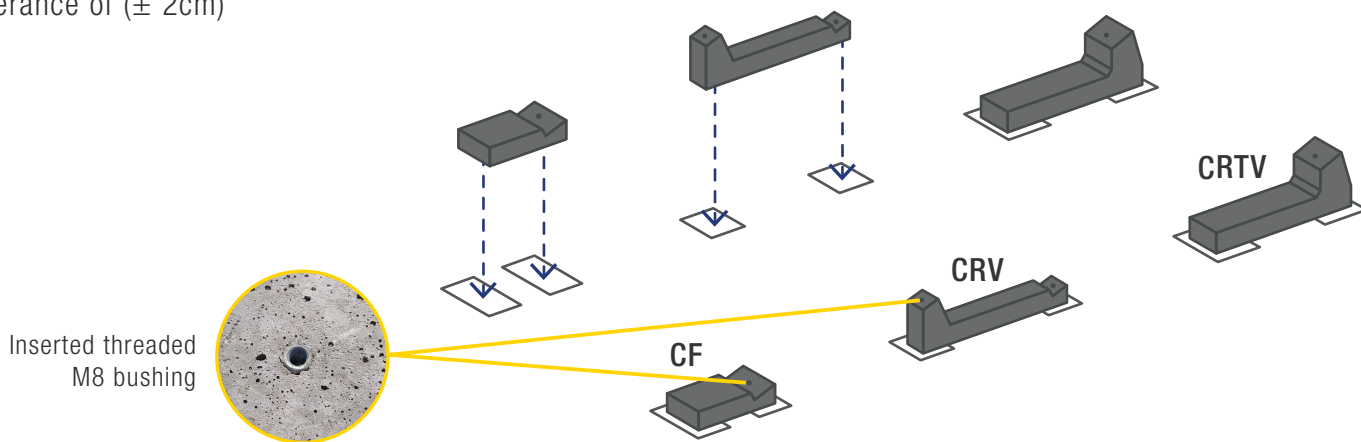

Phase 3: Installation of photovoltaic panels

Once the first panels have been positioned, they must be fixed with the supplied clamps and then gradually proceed with the installation of the subsequent rows.

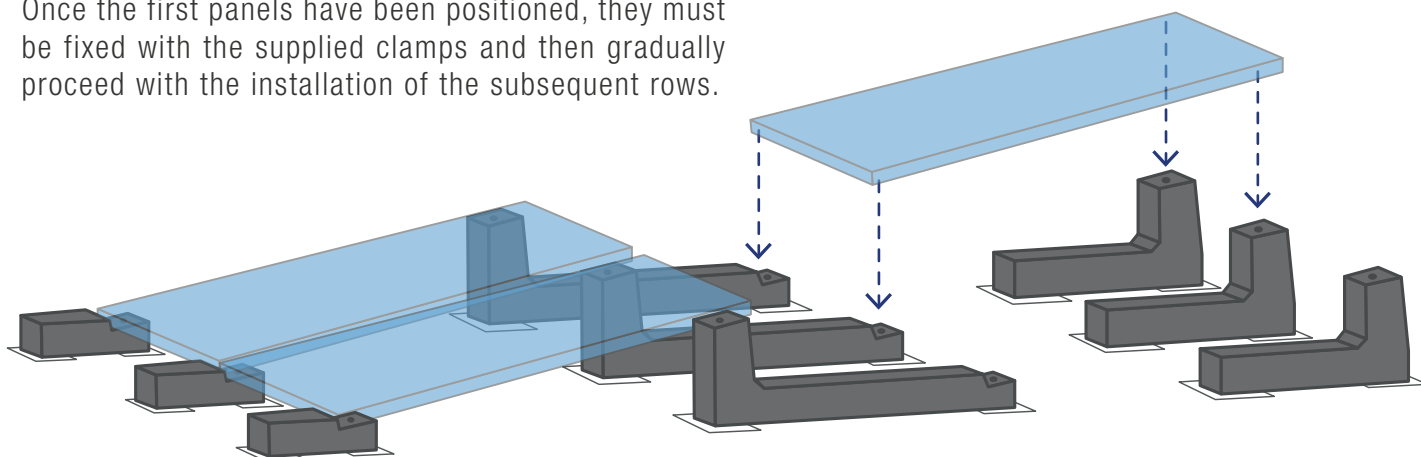

SUN BALLAST ASSEMBLY SEQUENCE

CONNECT SYSTEM

Valid for connect: **10°** - Panels orientation: **VERTICAL** - Double ballast: **YES** - Cablowind: **NO** -
Additional Weight: **YES**

Phase 4: Fixing the panels with terminal and central clamps

Use the terminal and central clamps prepared as indicated on the dedicated sheet.

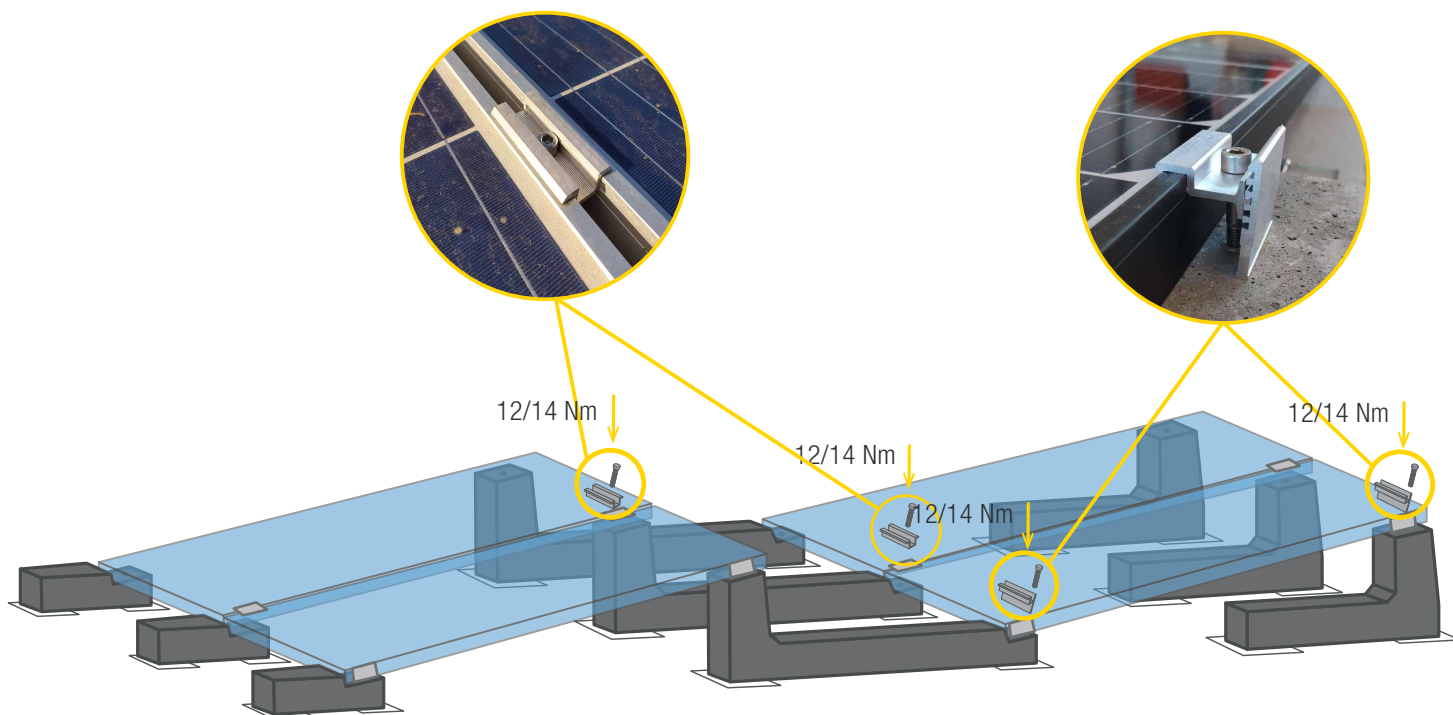

Warning: system recommended for panels with a minimum length of 156 cm and a maximum length of 175 cm.

The applied torque must refer to the mechanical standard conforming to the bolt in use: with M8 stainless steel bolts use a tightening torque of 12/14 Nm.

Avoid impact wrenches: it is advisable to also consult the information indicated in the assembly sheet of the panel manufacturer.



SUN BALLAST ASSEMBLY SEQUENCE

EAST-WEST SYSTEM

Valid for: **3°K, 5°, 10°, 11°, 15°, 20°, 30°.1** - Junction plate: **3°K, 5°**, - Panels orientation: **HRIZZONTAL** - Double ballast: **YES** - Cablowind: **NO**

Phase 1: Laying of the sheaths

It is recommended to use a wire to position the sheaths linearly with respect to the system and to lay the same at the ends of the support surface of the ballast.

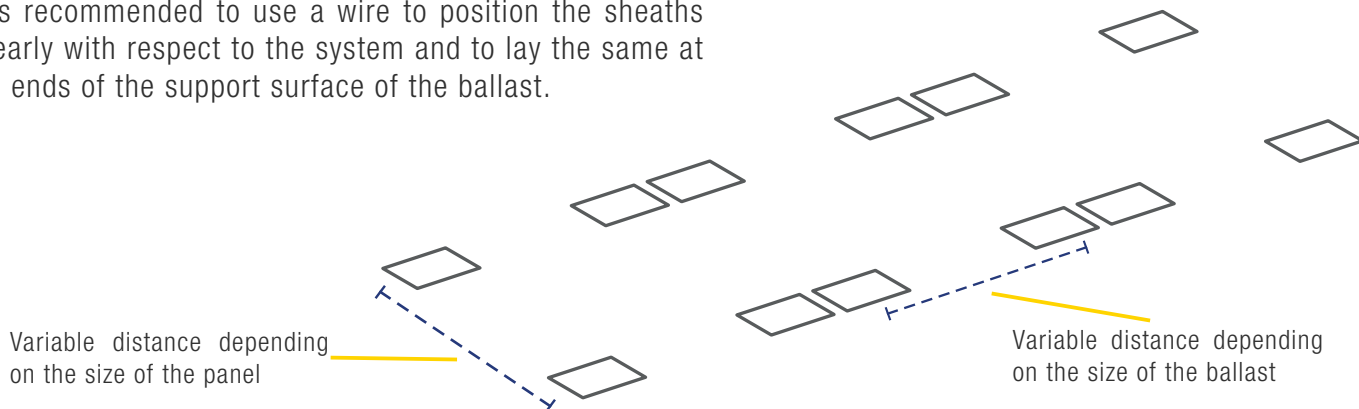

Phase 2: Laying of the ballast on the sheaths

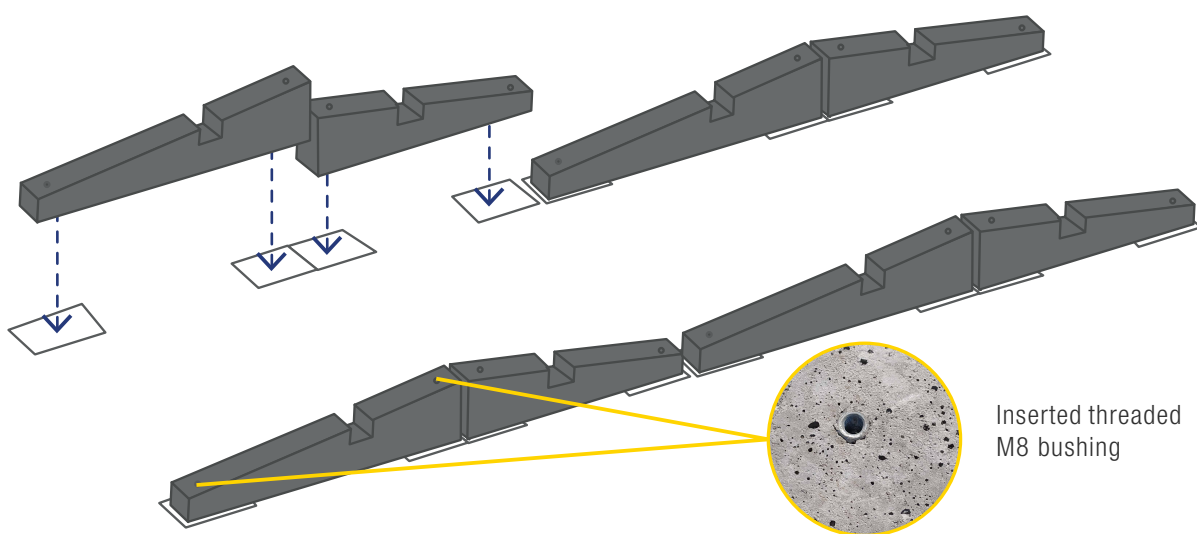

Phase 3- Position the junction plate

Position the junction plate in correspondence with the holes of the ballasts.

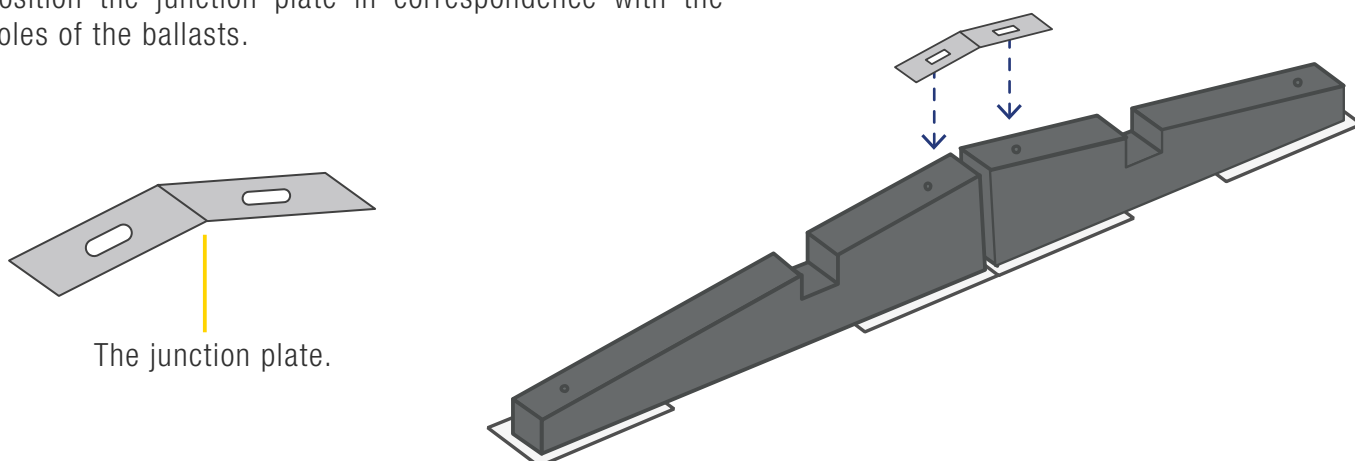

SUN BALLAST ASSEMBLY SEQUENCE

EAST-WEST SYSTEM

Valid for: **3°K, 5°, 10°, 11°, 15°, 20°, 30°.1** - Junction plate: **3°K, 5°**, - Panels orientation: **HRIZZONTAL** - Double ballast: **YES** - Cablowind: **NO**

Phase 4: Fixing the panels with terminal and central clamps

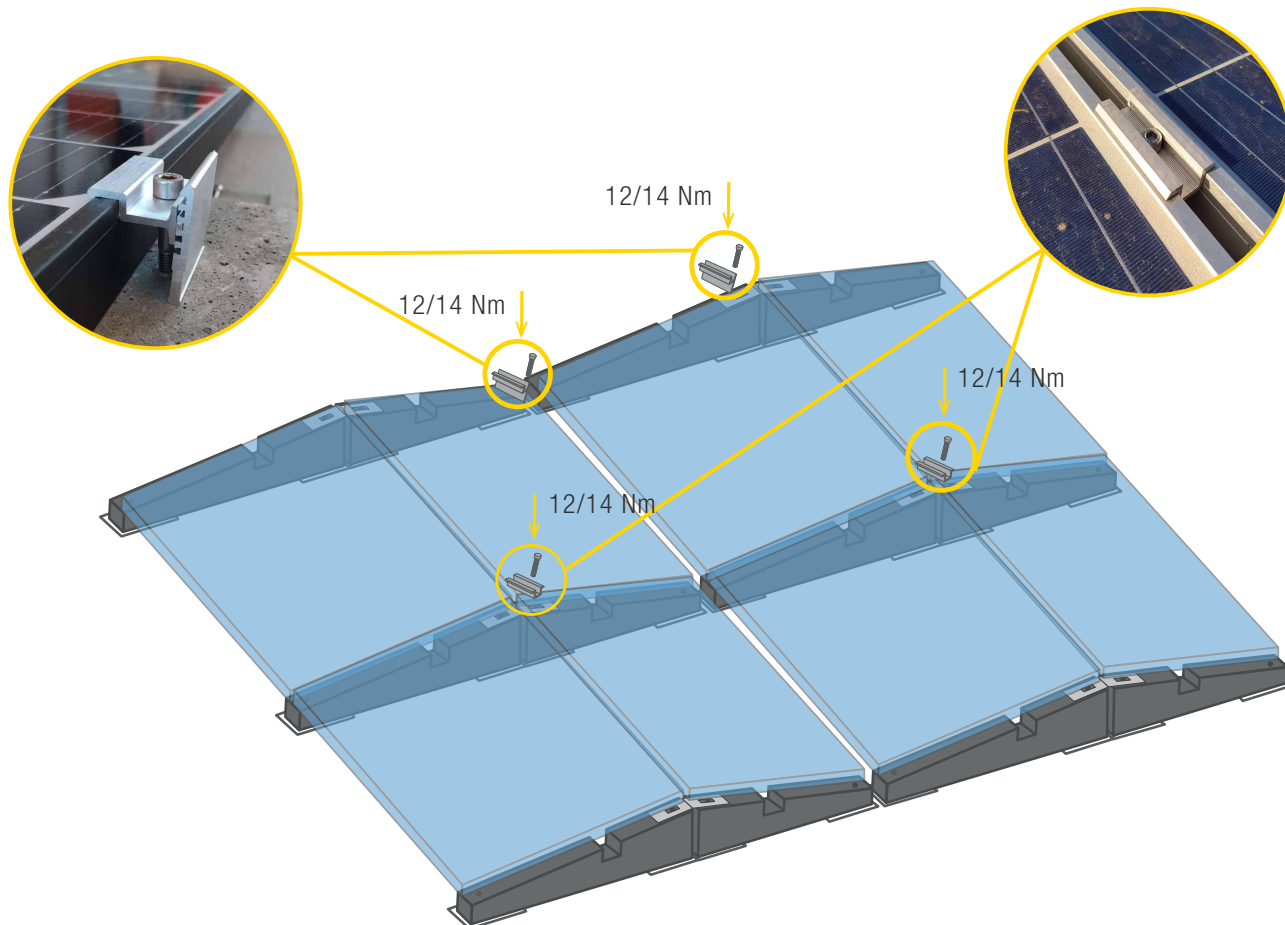

The applied torque must refer to the mechanical standard conforming to the bolt in use: with M8 stainless steel bolts use a tightening torque of 12/14 Nm.

Avoid impact wrenches: it is advisable to also consult the information indicated in the assembly sheet of the panel manufacturer.

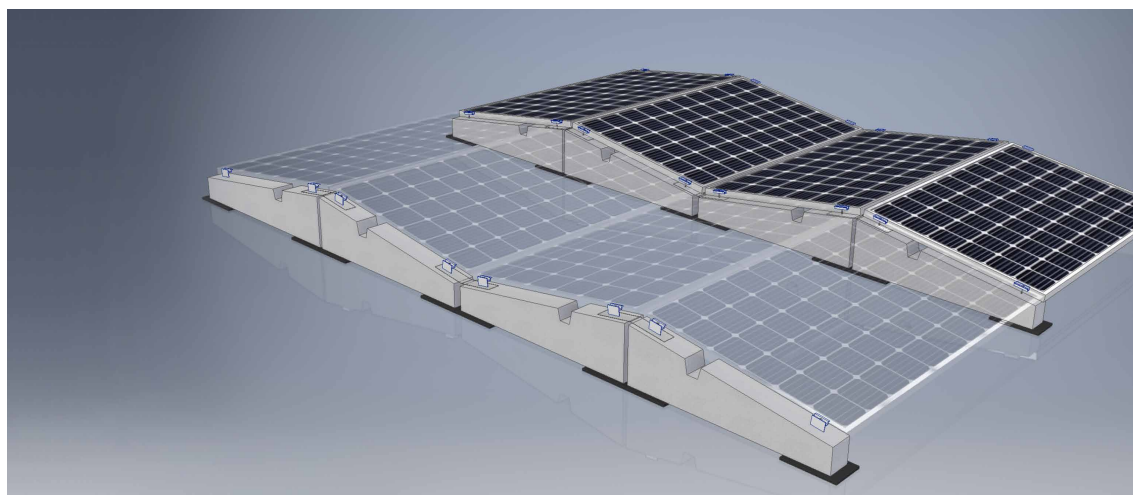

SUN BALLAST ASSEMBLY SEQUENCE

CABLOWIND

Valid for: 5°, 10°, 11°, 15°, 20°, 30°.1 - Additional Weight: YES

Phase 1: Positioning of the sheaths for the cablowind bracket

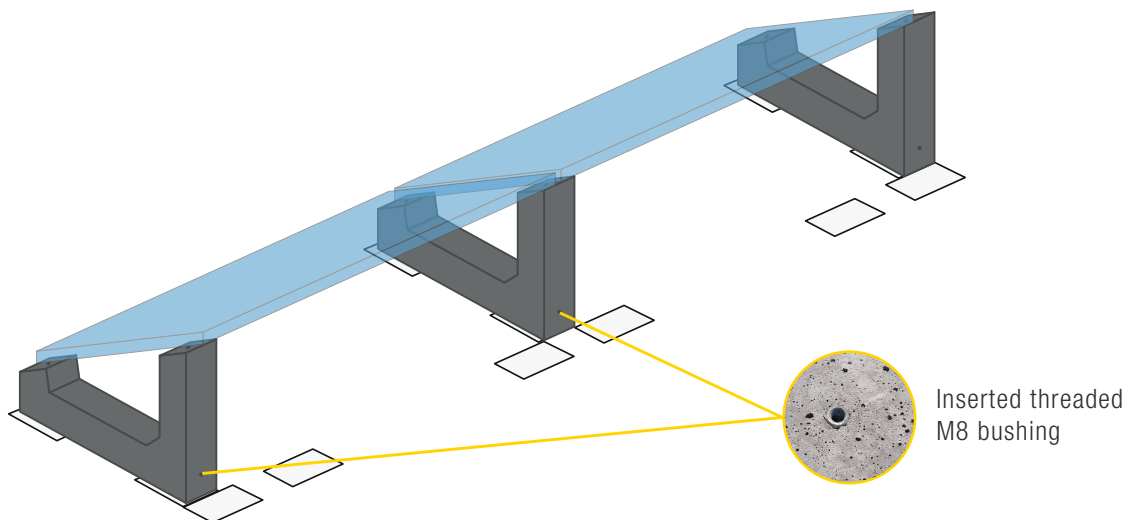

Phase 2: Fixing the cablowind bracket in the rear ballast bushing

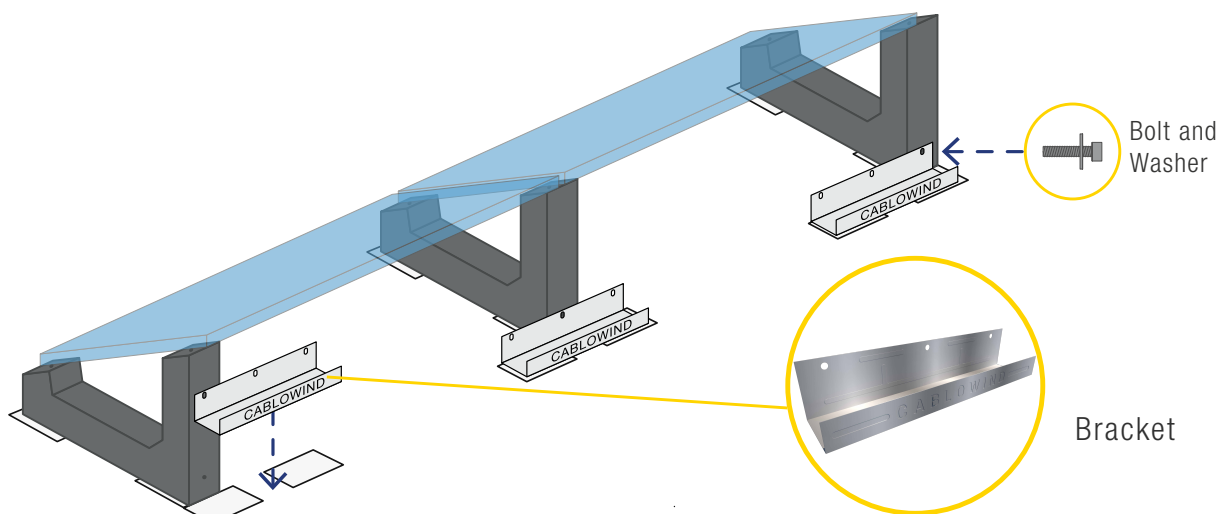

Phase 3: Positioning of the cablowind inside the brackets

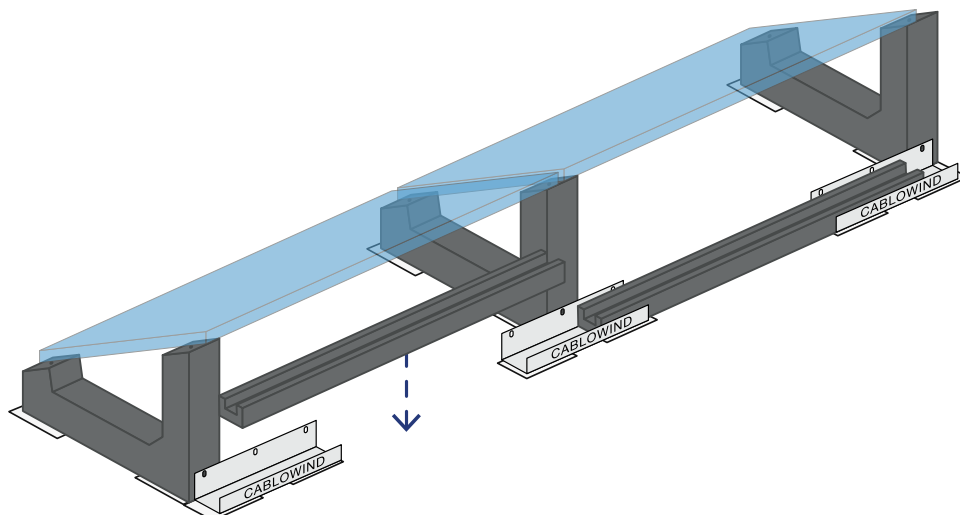

SUN BALLAST ASSEMBLY SEQUENCE

CABLOWIND

Valid for: 5°, 10°, 11°, 15°, 20°, 30°.1 - Additional Weight: **YES**

Phase 4: Positioning of the cables inside the cablowind

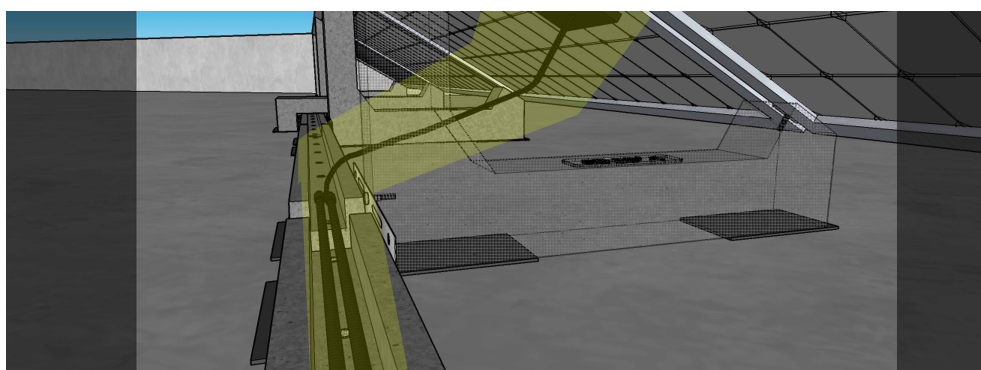
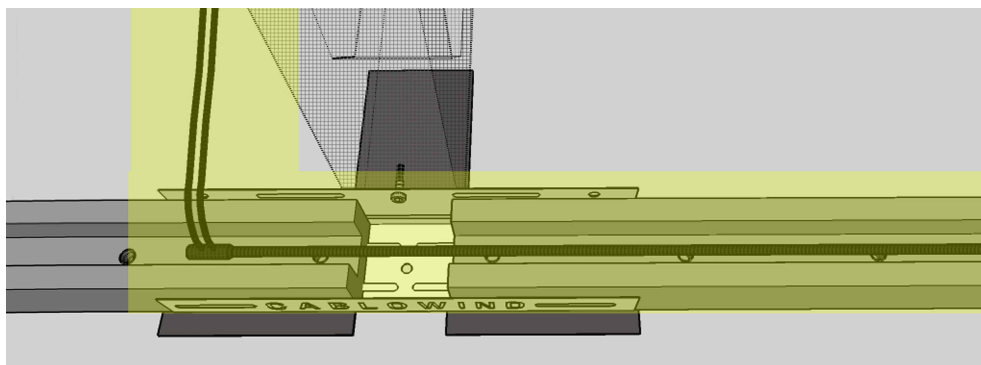

SUN BALLAST ASSEMBLY SEQUENCE

U-SHAPED ADDITIONAL WEIGHT

Valid for Connect system: 10°, 15°, 20°, 30°, 10° vertical and 5° sail-shaped connect -

Valid for standard system: 10°, 15°, 20°, 30°.1 - Cablowind: SI

For Connect System

Place the additional 'interlocking' weights on the central ballasts concerned according to the design

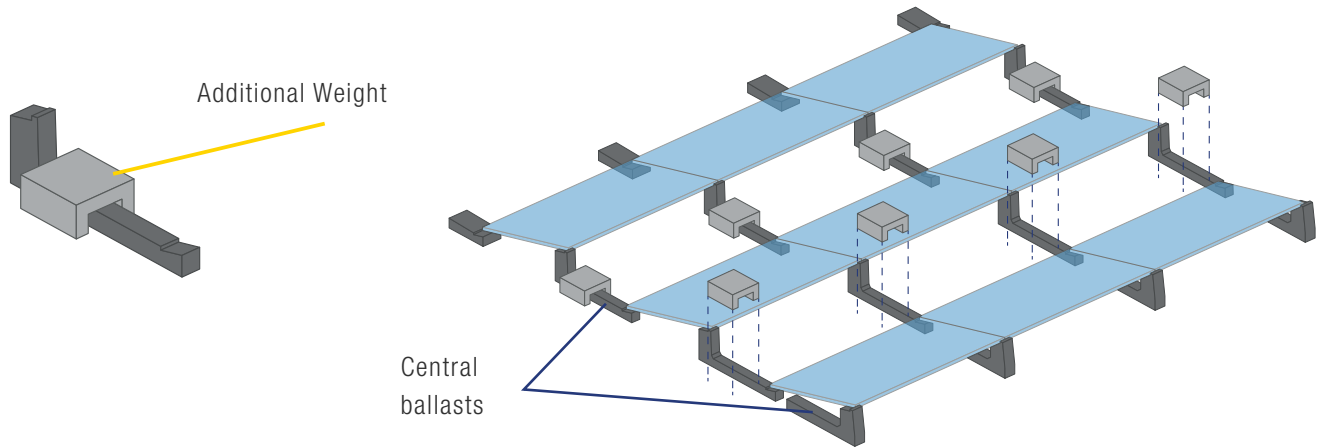

For Standard System

Place the additional 'interlocking' weights on the ballasts concerned according to the design

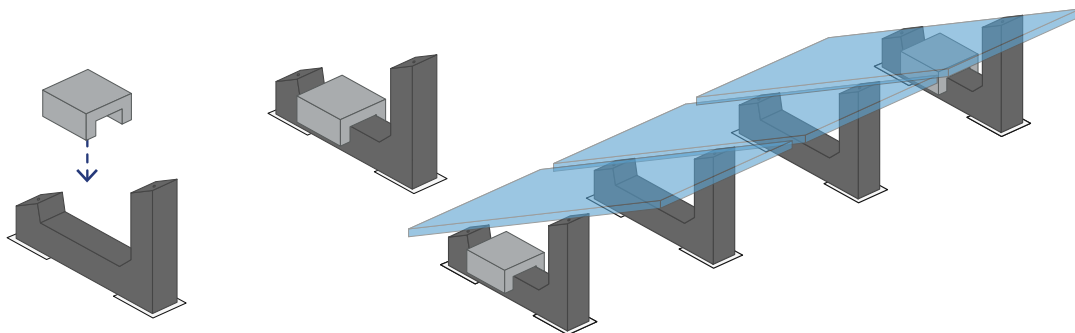

For Cablowind System

Place the additional 'interlocking' weights on the cablowind concerned according to the design

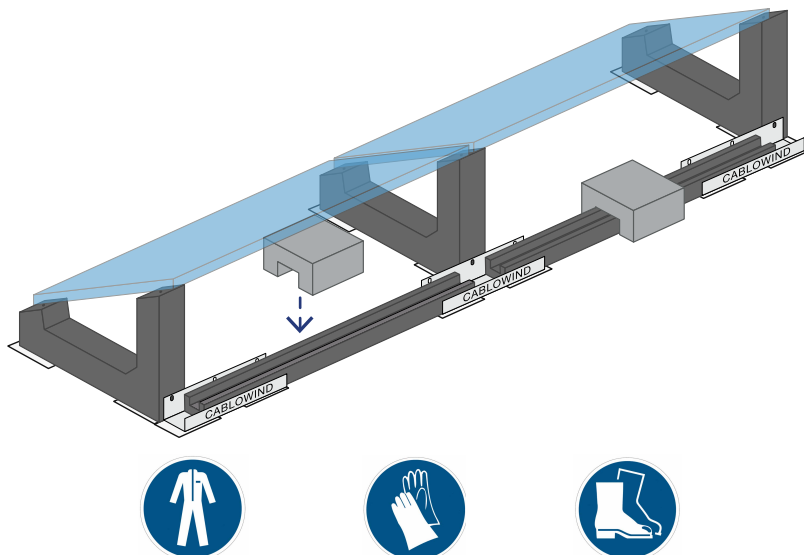

SUN BALLAST ASSEMBLY SEQUENCE

ADDITIONAL WEIGHT

Valid for standard system: 0°.K - If it is foreseen by the project

Additional weight for standard system 0°.K

Arrange the 0.K ballasts as foreseen by the project in their additional weight function.

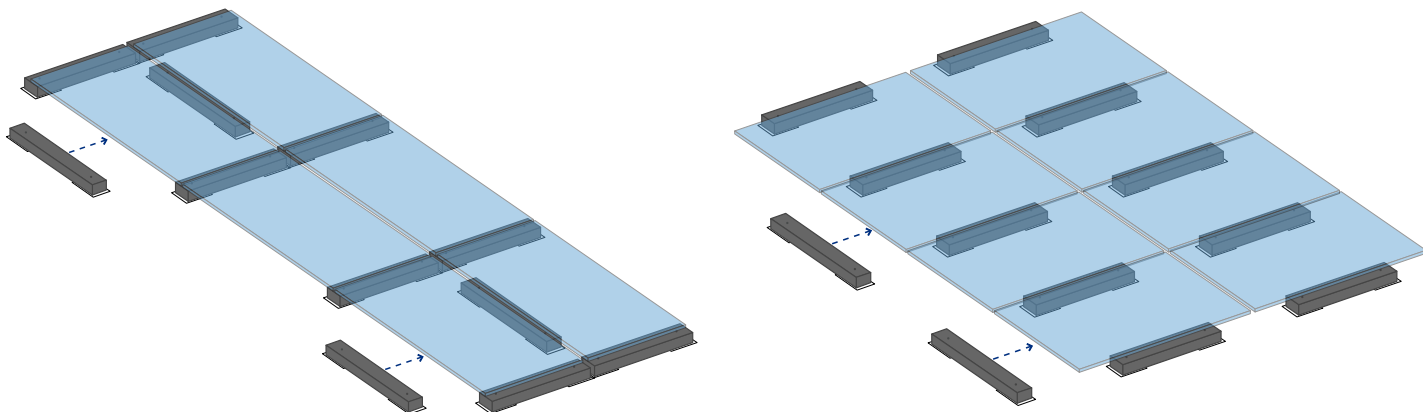

Attachment of additional weights with terminal and central clamps

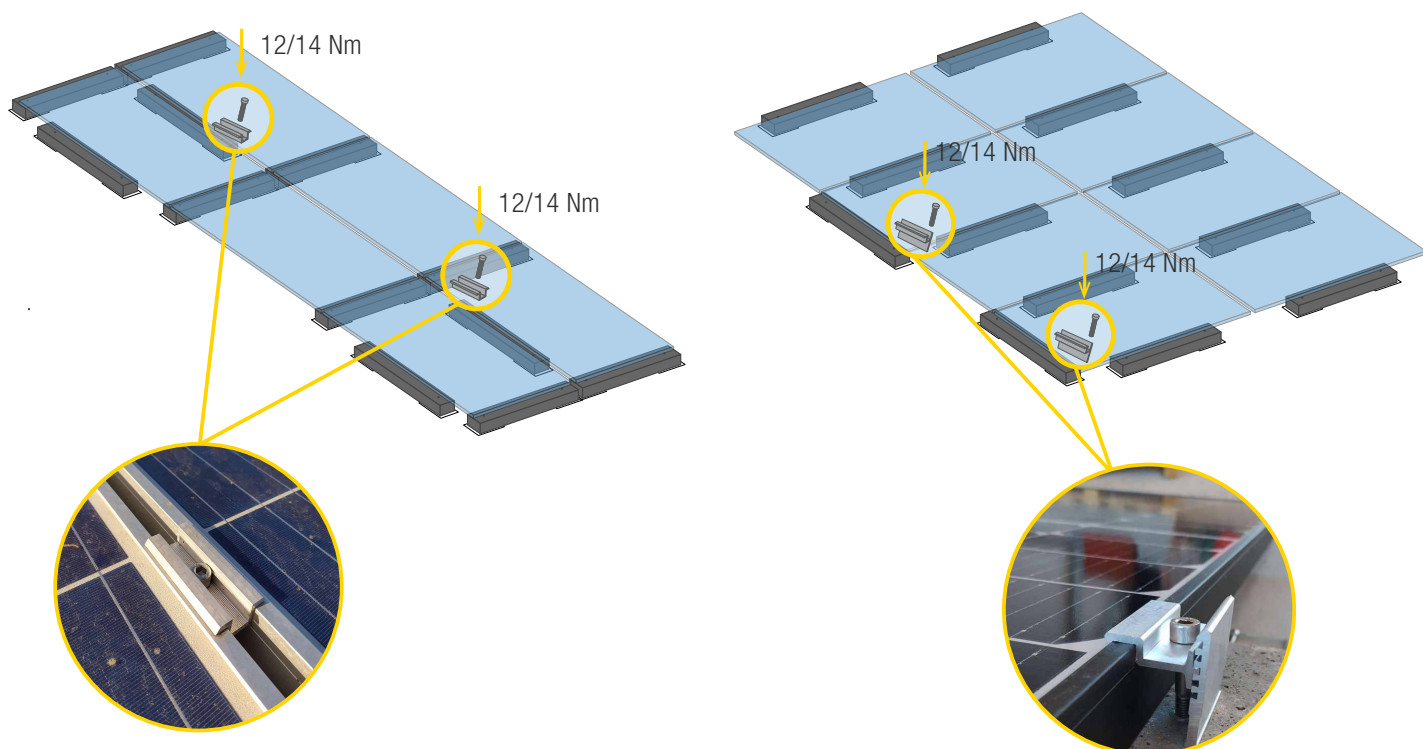

The applied torque must refer to the mechanical standard conforming to the bolt in use: with M8 stainless steel bolts use a tightening torque of 12/14 Nm.

Avoid impact wrenches: it is advisable to also consult the information indicated in the assembly sheet of the panel manufacturer.



SUN BALLAST ASSEMBLY SEQUENCE

DOUBLE BALLAST

Valid for all Sun Ballast systems - If required by the project

Phase 1: Installation of the system

Refer to the assembly sheet of the purchased system.
Position the main ballasts, those on which the panel will be fixed.

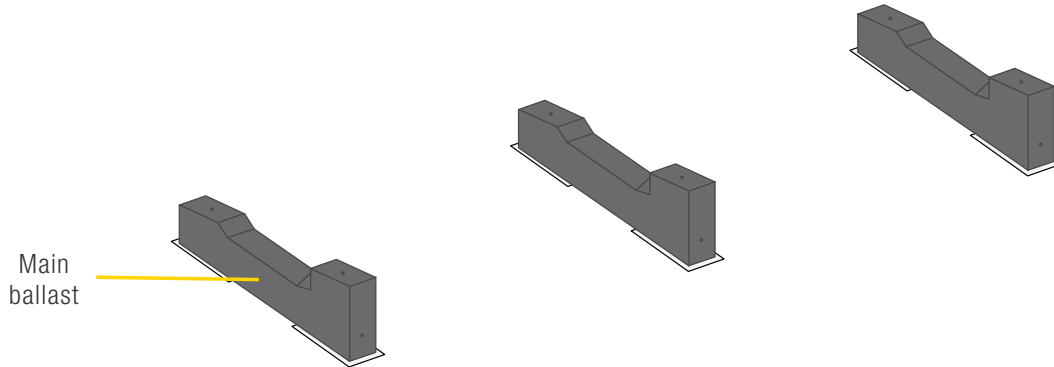

Phase 2: Double ballast

Place the additional weight next to the main weight involved

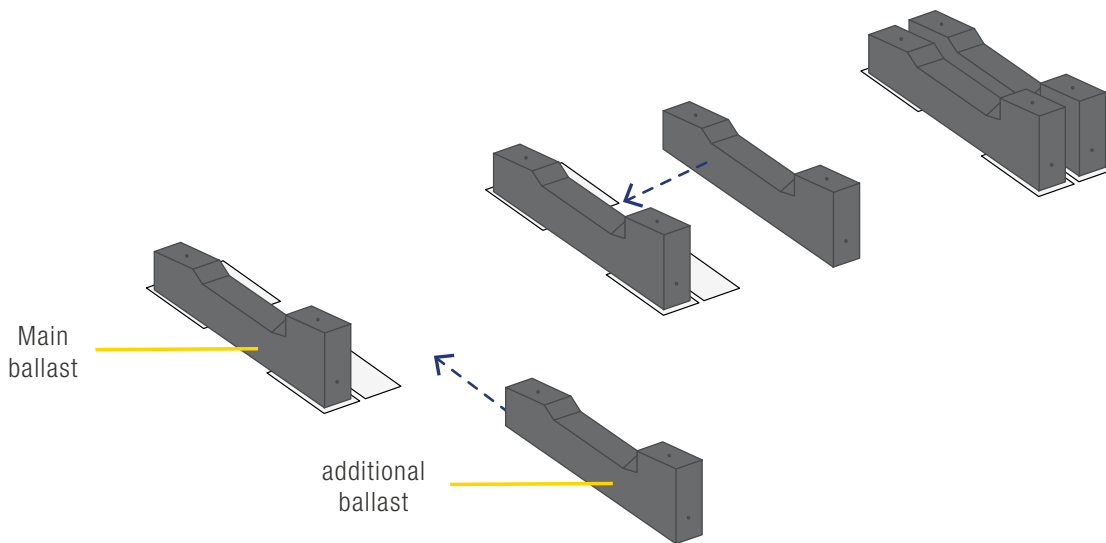

Phase 3a: Attach the junction plate

Rear positioning of the junction plate.
If it is present refer to the project.

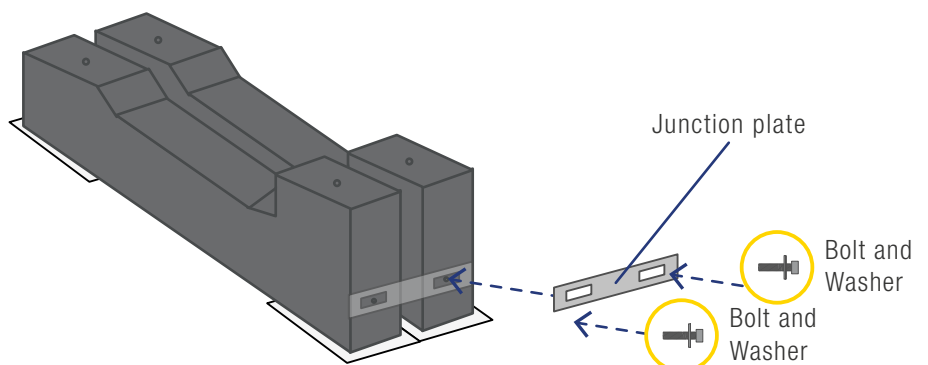

SUN BALLAST ASSEMBLY SEQUENCE

DOUBLE BALLAST

Valid for all Sun Ballast systems - If required by the project

Phase 3b: Attach the junction plate

Superior positioning of the junction plates.

When the positioning of the junction plates is in the upper part, only an additional bolt with washer is required to be used on the additional ballast. The junction plate is fixed to the primary ballast with the kit delivered with the system.

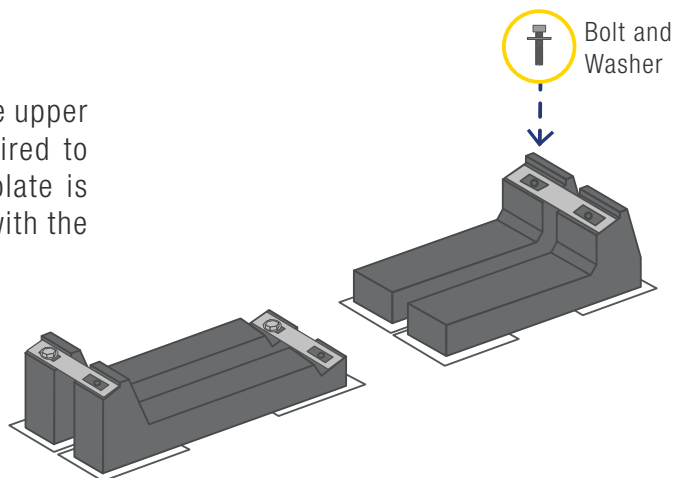

Phase 4: Fixing panels - Terminal and central clamps

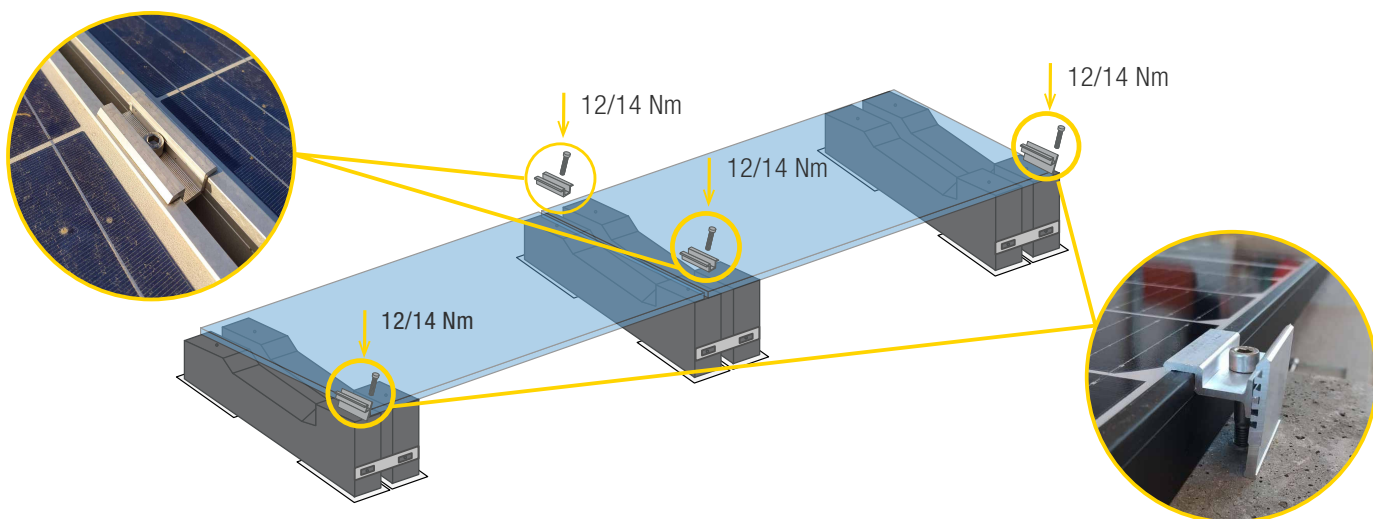

Horizontal or vertical panels depending on the design



SUN BALLAST ASSEMBLY SEQUENCE

POLYURETHANE FOAM

Valid for all Sun Ballast systems - If required by the project

To apply the polyurethane foam, please remember that the application surfaces must be thoroughly clean.

Phase 1: Lay system

Refer to the assembly sheet of the purchased system.
Before applying the foam, check if that the implant is correctly positioned.

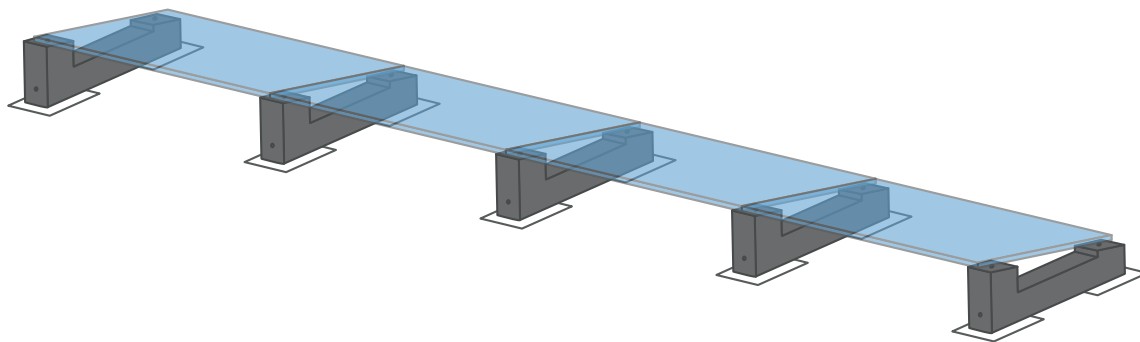

Phase 2: Apply the foam with the special dispenser under the ballast

Implant without sheaths

Implant with sheaths

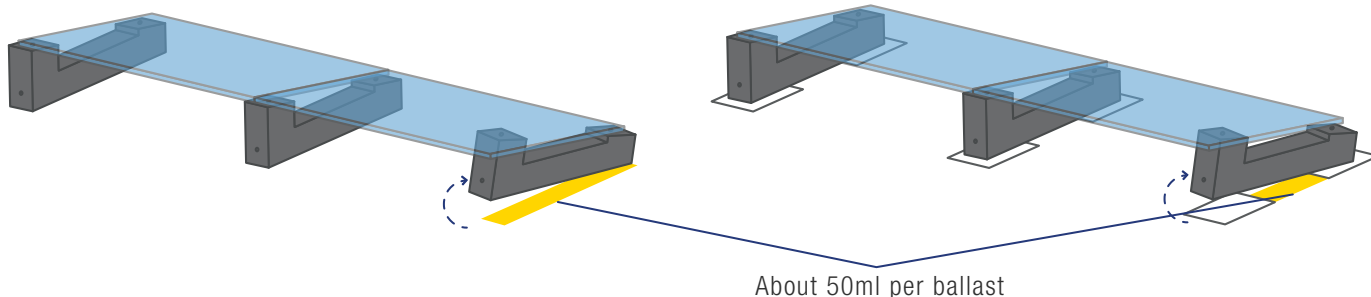

Phase 3: Repeat the operation with all the ballast involved

Implant without sheaths

Implant with sheaths

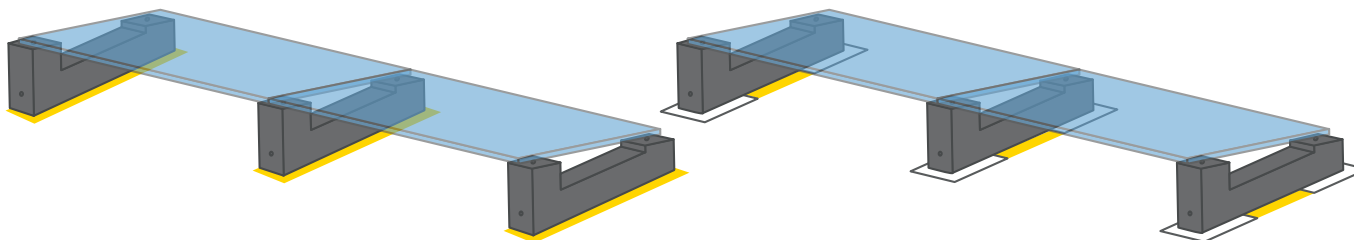

SUMMARY TABLE

STANDARD SYSTEM

Standard System	Orientation	Double Ballast	Additional Weight	Cablowind	NO-FLEX
0°.K	V / H	Yes	No	No	No
0°.H20	V / H	Yes	Yes	Yes	No
0°.HI	V / H	Yes	Yes	Yes	No
3°.K	V / H	Yes	No	No	Yes
5°	V	Yes	No	Yes	No
5°	H	Yes	No	Yes	Yes
5°.2	V / H	Yes	Yes	Yes	Yes
5°.3	V / H	Yes	Yes	Yes	Yes
5°.4	V / H	Yes	Yes	Yes	Yes
5°.5	V / H	Yes	Yes	Yes	Yes
5°.6	V / H	Yes	Yes	Yes	Yes
10°.SHED	V / H	Yes	No	No	No
10°.V	V / H	Yes	Yes	Yes	Yes
10°.L	V	Yes	Yes	Yes	No
11°.K	H	Yes	No	Yes	No
11°.2	H	Yes	Yes	Yes	No
11°.3	H	Yes	Yes	Yes	No
15°	V / H	Yes	Yes	Yes	Yes
20°	V / H	Yes	Yes	Yes	Yes
30°.1	V / H	Yes	Yes	Yes	Yes

CONNECT SYSTEM

Connect System	Orientation	Double Ballast	Additional Weight	Cablowind	NO-FLEX
5°	H	Yes	No	No	Yes
5° Sail	H	Yes	Yes	No	No
10°	V / H	Yes	Yes	No	Yes
15°	H	Yes	Yes	No	Yes
20°	H	Yes	Yes	No	Yes
30°	H	Yes	Yes	No	Yes

The summary tables do not replace the technical report, they are indicative of the systems that can be installed.

RESPONSIBILITY

EAST-WEST SYSTEM

East-West System	Orientation	Double Ballast	Additional Weight	Cablowind	NO-FLEX
3°.K	H	Yes	No	No	Yes
5°	H	Yes	No	No	Yes
5°.2	H	Yes	Yes	No	Yes
5°.3	H	Yes	Yes	No	Yes
5°.4	H	Yes	Yes	No	Yes
5°.5	H	Yes	Yes	No	Yes
5°.6	H	Yes	Yes	No	Yes
10°.V	H	Yes	Yes	No	Yes
10°.L	H	Yes	Yes	No	No
11°.K	H	Yes	No	No	No
11°.2	H	Yes	Yes	No	No
11°.3	H	Yes	Yes	No	No
15°	H	Yes	Yes	No	Yes
20°	H	Yes	Yes	No	Yes
30°.1	H	Yes	Yes	No	Yes

SAIL-SHAPED SYSTEM

Sail-shaped System	Orientation	Double Ballast	Additional Weight	Cablowind	NO-FLEX
5°	V	Yes	No	Yes	No
5°	H	Yes	No	No	Yes
5°.2	V	Yes	Yes	Yes	No
5°.2	H	Yes	Yes	No	Yes
5°.3	V	Yes	Yes	Yes	No
5°.3	H	Yes	Yes	No	Yes
5°.4	V	Yes	Yes	Yes	No
5°.4	H	Yes	Yes	No	Yes
5°.5	V	Yes	Yes	Yes	No
5°.5	H	Yes	Yes	No	Yes
5°.6	V	Yes	Yes	Yes	No
5°.6	H	Yes	Yes	No	Yes
11°.K	H	Yes	No	Yes	No
11°.2	H	Yes	Yes	Yes	No
11°.3	H	Yes	Yes	Yes	No

WARRANTY**THE CIVIL RESPONSIBILITIES**

Basic Srl does not undertake any control activities on the installation of ballasts and panels, which shall follow the assembly instructions indicated in this manual, therefore it declines any responsibility for damage due to improper use of the Sun Ballast system.

The civil responsibilities of building

Let's talk about the current regulatory landscape

Introduction

The topic of the civil liabilities in the field of housebuilding is rather delicate and blurred, because of the countless technical norms which currently create considerable confusion. Innumerable are the duties to fulfil, it is unclear who shall take charge of the onerous duty of verifying and sanctioning though.

Non-contractual liability and art. 1669**Civil Code**

Joint responsibility of contractor, of works manager and of client himself. Fundamental is the art. 1669 Italian C.C. "Deterioration and defects of immovable things" which establishes: "In the case of buildings or other immovable property intended by their nature to last for extended periods of time, if, in the course of ten years after completion, the work, due to soil or construction defects, deteriorates in whole or in part, or presents a clear danger of ruin or serious defects, the contractor shall be liable to the client and its assignees, provided that the report is made within one year from its identification. The client's right shall lapse within one year of the report." Although at a first reading the aforementioned article entrusts the contractor with the exclusive responsibility, this is not the case: the orientation now consolidated by the Court of Cassation identifies in art. 1669 of the Civil Code a form of non-contractual liability which, therefore, goes beyond the limits of the contractual relationship between the parties and involves, in addition to the contractor, the designer, the works manager and the client himself who has directly managed the construction of the property.

Everyone can be called upon to jointly and severally compensate the damage that has occurred, when their respective conduct (actions or omissions), although independent of each other, have efficiently contributed to the creation of the harmful event. (Cass. N.20294/2004-Cass.n.12367/2002-Cass.n.972/2000). For further clarity, please remark: the supplier of materials used in the construction of the building cannot be included in the case of non-contractual liability indicated above, since its performance is limited to the delivery of the products without participating, therefore, in the construction of the building. (Cass. n. 13158/2002)

The manufacturer**Responsibilities and guarantees**

The article 1° of the DPR n. 224 of 1988 enacts the general principle according to which "the producer is responsible of the damage caused by a defect of their product" towards all consumers: whether professionals, companies and authorized personnel, or private citizens.

The producer is also required to:

- Specify the indications and limits of use of the products, providing any necessary warnings and legal obligations,
- To enter the data measured in quality control and within the limits of responsibility,
- Have third party companies carry out tests on the products, which recognize their functionality, and request ITC/ETA certification on systems and CE marking, where mandatory.

WARRANTY**TECHNICAL REQUIREMENTS DECLARATION SUN BALLAST - BALLAST**

Headquarters: Via della Costituzione 26-42028 Poviglio (RE)- Italia

Denomination: Ballasts in precast unreinforced concrete (Inside there is an iron rod to increase mechanical elasticity)

Article: Sun Ballast (Patented system)

Technical characteristics:

- Exposure class: XC4 unless otherwise specified
- Strength class: C32/40
- Minimum cement content: 340 kg/m²
- Class of fire resistance C A1 (as established by the Decree of the Italian Ministry of the Interior on the 14th January 1985)
- Maximum depth of water (H2O) penetration under the pressure 500 kPa: 15 mm
- Medium depth of water (H2O) penetration under the pressure 500 kPa: 10 mm
- Determination of the tensile/pull-out strength of the buckle M8 embedded in the concrete element through direct tensile test on the bolt M8 which is screwed in the buckle
- Minimum tensile strength of the test at 15 KN (1530 kg) without any slipping of the buckle inserted in the Sun Ballast ballast
- Weight tolerance +/-5%

BASIC SRL STATES THAT

The production complies with all instructions and procedure of the quality management system certified according to the UNI EN ISO 9001:2015. Any modification to the product covered by this declaration made without the authorisation of the manufacturer shall render this declaration of technical conformity null and void.

Poviglio (RE) Italia

The legal representative

Basic Srl

Via della Costituzione, 26 -42028 Poviglio

Tel/Fax 0522/960926

P.iva 02557770357 REA: 292573

info@sunballast.it

www.sunballast.it

WARRANTY

WARRANTY ON SUN BALLAST PRODUCT - BALLAST

Basic Srl guarantees the functionality over time of “**Sun Ballast**” supports for photovoltaic panels on flat roofs, produced and marketed by the Company itself, for a period of **25 years** from the date of purchase.

Subject of the warranty

Basic Srl guarantees the resistance to corrosion derived by weather conditions (rain, ice, temperature fluctuations, salinity) of the supports, from the same produced and marketed, for photovoltaic panels on flat roof for a period of 25 years from the date of purchase.

Terms and conditions of the warranty

The Warranty will be operational only if all the following conditions are applied:

1. The system must be fully realized with the range of accessories supplied by Basic:
 - Central brace in aluminum
 - Terminal brace in aluminum
 - Screw for central and terminal brace INOX A2m
 - Sheath
 - Potential accessories.
2. The ballast system shall be installed in a workmanlike manner and in compliance with the specific installation instructions of Basic Srl which are into force at the moment of purchasing and written in the technical specifications and in these assembly instructions.
3. If the ballasted system has been built using materials and components other than those specified in point “1”, they must in any case have been marketed by Basic Srl. Any damage due to products not marketed by Basic Srl is excluded from this warranty.

This warranty is provided to the client with every order placed by the client. In the event of damage attributable to the terms stated in this warranty, and excluding any other obligation or reimbursement, Basic Srl:

- Shall provide a replacement product without additional charges. If the product is no longer in production, Basic Srl shall supply an equivalent product of equal value,
- shall provide directly, through personnel chosen by the same and at its own expense, to restore the original functionality, possibly after an inspection by one of its representatives who will assess and determine the type of intervention required.

ESCLUSIONS

This Warranty does not include:

- damages caused by soil movements, settlement of the structure of the immovable property or movements of the structure,
- damages caused by an incorrect use or maintenance of the structure, by activities, tampering or changes made by third parties,
- accidental or voluntary damages, actions of war included,
- damages caused by lightnings,
- damages caused by natural disasters,
- damages derived from a wrong installation,
- damages derived from a wrong dimensioning.

Any other obligation or indemnity to be paid by Basic Srl is expressly included, and Basic Srl shall not be held liable for any direct or indirect damage to goods, movable and immovable property, rights or activities of the person guaranteed to third parties.

WARRANTY

WARRANTY ON SUN BALLAST PRODUCT - BALLAST

Procedure

The request for activation of this warranty shall be made in writing and shall be received within 30 days from the date on which the damage becomes evident. The notice shall be accompanied by an evidence of purchase (copy of the invoice), shall state the details of the declared damages and shall be sent to: info@sunballast.com, to your marketing representative or on our website: <http://www.sunballast.it/en/contacts> in any case, the client's rights against its direct seller are not affected, in accordance with the applicable legislation on warranty in the sale of consumer goods art. 1490 of the Italian Civil Code.

This warranty is transferable to subsequent owners without prior notice from Basic Srl.

Poviglio (RE) Italia

The legal representative

Basic Srl

Via della Costituzione, 26 - 42028 Poviglio
Tel/Fax 0522/960926
P.iva 02557770357 REA: 292573
info@sunballast.it
www.sunballast.it

MAINTENANCE

PLANT INSTALLATION LOG

Data relating to the installing company

Company name:	
Address:	
ZIP:	
Location:	
VAT number:	

Plant data

Customer:							
Place of installation:							
Plant capacity:							
Ballast model:							
Use of accessories:							
Module dimensions:							
Presence and height of perimeter parapet:							
North:		South:		East:		West:	
Distance from the parapet:							
Residual load-bearing capacity of the slab:							
Roof inclination:							
Altezza edificio :							

Locality of the plant: 1,2,3,4,5,6,7,8,9: Vb0 m/s reference wind speed: 25; 26; 27; 28; 29; 30; 31

GROUND ROUGHNESS CLASS

<ul style="list-style-type: none"> • CLASSE A <p>Urban areas where at least 15% of the surface is covered with buildings whose average height exceeds 15m</p>	<ul style="list-style-type: none"> • CLASSE B <p>Wooded, industrial, suburban, and urban areas (not in class A)</p>	<ul style="list-style-type: none"> • CLASSE C <p>Areas with distributed barriers (trees, houses, walls, fences...): areas whose roughness is not attributable to A, B, D classes</p>	<ul style="list-style-type: none"> • CLASSE D <p>Areas without barriers (open land, airports, agricultural areas, pastures, sandy areas, wetlands, surfaces covered in snow or ice, lakes...)</p>
--	--	---	--

WARRANTY

FAC SIMILAR PLANT INSTALLATION EXECUTION REPORT

Verifications	Positive / Negative	Note
Check the condition of the roof, before positioning the system, to ensure its suitability for installation and the absence of existing defects (tears, joints, detached sheath and any obstacles not described in the design phase).		
Check that the products installed correspond as indicated on the design, report or order confirmation.		
Check that the height of the building, the railing, the distance from the roof edge, the distance between the rows, correspond to those indicated in the system layout.		
In the case of changes with respect to the project, check the need for additional accessories and related installation and, if necessary, update the project.		
Check that potential accessories are properly placed in order to improve the resistance to wind loads.		
Check that all components are properly locked.		
Check that the worksite is clean and no component or packaging is left onsite that could damage the work surface.		
Pictures of the installed plant.		

Place and date

Firma del tecnico



SUN BALLAST

Supporting solar innovation
Patented systems

FOLLOW US ON:



For information and quotes:

✉ info@sunballast.com

☎ +39 0522 960926

🌐 www.sunballast.it

Where are we:

📍 Basic Srl - Via della Costituzione, 26 42028 Poviglio (RE) Italy - P.Iva: 02557770357

